



South Lake County Fire Protection District
— in cooperation with —
California Department of Forestry and Fire Protection

P.O. Box 1360 Middletown, CA 95461 - (707) 987-3089

BOARD OF DIRECTORS' REGULAR MEETING AGENDA

7:00 P.M., August 18, 2020

Middletown Fire Station, 21095 Highway 175

NOTICE: Pursuant to Governor Gavin Newsom's Executive Order N-29-20, meetings will be held teleconference. Teleconference participation by: Directors Rob Bostock, Jim Comisky, Devin Hoberg, Madelyn Martinelli and Eric Redford. Teleconference locations are on file at District Office, 21095 Highway 175, Middletown, CA 95461.

Due to the Coronavirus (COVID-19), Residents are encouraged to attend the Board of Directors' meeting via the application, ZOOM.

ZOOM MEETING INFORMATION:

Website: <https://zoom.us/join>

Meeting ID: 823 3647 1460

Call in Phone Number: (669) 900 6833

Public comments may be made remotely by emailing boardclerk@southlakecountyfire.org (prior to 7:30 pm) or via ZOOM website or phone application. Comment period is three (3) minutes per person. Total comment period is not to exceed fifteen (15) minutes, unless extended at the discretion of the Board. This rule does not apply to public hearings. Comments are allowed before any action is taken by the Board on any specific issue.

NON-TIMED ITEMS

A. OPEN MEETING:

A1. Call to Order:

A2. Pledge of Allegiance:

A3. Roll Call:

A4. Motion to approve agenda:

MOVED _____ SECONDED _____ YES ___ NO ___ ABSTAIN ___

B. CITIZENS' INPUT:

(Any person may speak for three minutes about any subject of concern provided it is within the jurisdiction of the Board of Directors and is not already on the today's agenda. Prior to this time speakers are asked to fill out a form (giving name, city, and subject) available in the Clerk's Office or during Board meeting.)

C. COMMUNICATIONS:

C1. Reports:

C1.1. Fire Sirens

C1.2. SL Fire Safe Council

C1.3. Volunteer Firefighters' Association

- C1.4. Chief's Report
- C1.5. Financial Report
- C2. Directors' Activity and Committee Report

TIMED ITEMS

D. REGULAR ITEM:

D1. **PUBLIC HEARING:** Consideration for Resolution No. 2020-21-03, A Resolution Adopting Budget for Fiscal Year 2020-2021 (May 19, 2020 Approved FY 2020-21 Recommended Budget with increases, decreases). Placed on the agenda by Gloria Fong.

MOVED _____ SECONDED _____ YES ___ NO ___ ABSTAIN ___

D2. Consideration for Resolution No. 2020-21-04 A Resolution Directing Fire Chief, or Designee, to Certify and Request County of Lake to Collect Special Tax on the 2020-2021 County Tax Rolls. Placed on the agenda by Gloria Fong.

MOVED _____ SECONDED _____ YES ___ NO ___ ABSTAIN ___

D3. CLOSED SESSION

Anticipated Litigation (one case) (Government Code Section 54956.9(b)).

REPORT OUT ON CLOSED SESSION

D4. Consideration for Resolution No. 2020-21-05, A Resolution Authorizing the Fire Chief to Execute Agreements for Participation in the Intergovernmental Transfer of Public Funds Program for the Service Periods, July 1, 2019 through June 30, 2020, and July 1, 2020 through December 31, 2020. Placed on agenda by Gloria Fong.

MOVED _____ SECONDED _____ YES ___ NO ___ ABSTAIN ___

D5. Surplus 2003 Ford Ambulance (License No 1155086 remounted, given new License No. 1315441) in 2010. Placed on agenda by Battalion Chief Wink.

MOVED _____ SECONDED _____ YES ___ NO ___ ABSTAIN ___

E. CONSENT CALENDAR:

(Approval of consent agenda items are expected to be routine and non-controversial. They will be acted upon by the Board at one time without discussion. Any Board member may request that an item be removed from the consent calendar for later discussion.)

E1. Minutes presented:

E1.1. July 21, 2020 – Regular Meeting

E2. Warrants presented:

E2.1. August – preliminary

E2.2. July – corrected

MOVED _____ SECONDED _____ YES ___ NO ___ ABSTAIN ___

F. MOTION TO ADJOURN MEETING:

Posted August 14, 2020

South Lake County Fire Protection District

Fire Chief Notes – 8/15/2020

North Division Operations:

Following an extended rebuilt, Copter 104 is back at Boggs Mountain with full capabilities. The new landing pad with lights has been completed. The Firehawk is still anticipated to show up around December of this year.

Camp Operations:

Konocti Camp is experiencing impacts to crew numbers as a result of the Governor's early release program. Currently we have 3 crews staffed at both Camps, with numbers subject to change on a weekly basis. This impact is being felt statewide and is causing a change in how we staff fires.

South Lake Operations:

Albion Survey Services out of St. Helena has been chosen to do the land survey to prepare for future expansion considerations at Station 63.

Weiden Welding out of Lower Lake has been chosen to build a fire escape from the upstairs Station 63 bedroom.

The Red Chevrolet Ambulance conversion to a Type 6 is being completed and should be ready for pick up by the end of the month.

Recently, Station 60 has been experiencing multiple door failures, with ongoing repairs. Staff is working on a complete door replacement for the station, for consideration in the 2021 Fiscal Year. Our door systems at Station 60 are 30+ years old, are very expensive to repair, and extremely hard to work on. A recent window replacement cost over \$1000.00 because no vendor wanted to chance damaging the door that parts are not available for.

The Slurry Seal and Parking lot restriping was recently completed. While completing the work, the vendor inquired on the age of the pavement. When we responded that it is exceeding 30 years of age, he stated that around 30 years is when pavement loses the ability to retain the gravel because the age of the tar. A ballpark quote to remove out and replace what we have would be \$250,000.00 for budgeting. While this is not an immediate issue, within the next 5 years, this is something we may need to be consider.

Our new Medic 6311 is very close to being placed into service. Radios and wireless hotspot installations are two of the last things.

Horizon Construction has donated their time for the Station 64 remodel. COVID stopped the progress for many months. They are now hopeful that in the next two weeks they will make it back to install the floors, base board, door trim and etcetera. Staff will complete the final finish work.

Despite a small hiccup with notification, All ENSS Sirens have received their annual service and are all working.

The 2010 Red Ford Ambulance which has been next to the PCF shed for the last couple of weeks is headed to Richie Brothers Auction Yard in Dunnigan, to be auctioned off.

South Lake County Fire Protection District

Fire Chief Notes – 8/15/2020

The front-line ambulances have received the new patient loading systems from Stryker and are working well. The reserve Ambulance is also being outfitted with the system. The system is another positive improvement to employee and patient safety.

The 2015 Valley Fire Generator replacement Grant was closed out last week.

The LCFCA received a nearly \$900,000 FEMA Grant to purchase Scott SCBAs. South Lake is part of the grant and will receive funding to replace most of our fleet. Our match for our equipment will be 10% of the cost. More details to follow as we move forward with purchasing.

Just for information, on 8/13/2020 a water leak was discovered at Station 60. An unused irrigation valve failed and was possibly leaking for quite some time as it was in an unused area. There is a potential for this to impact our water bill for next month.

Fire Sirens:

No Report

PCF's:

No Report

End of Report

Paul Duncan – Fire Chief

CDF/SLCF INCIDENT TRACKING FORM

Month July 2020

Station 62

FA = False Alarm
 CR = Cancel & Return
 UTL = Unable To Locate
 AMA = Against Medical Advice
 CB = Code Blue (Full Arrest, CPR in Progress)
 LA = Lift Assist
 NMM = No Medical Merit (AMA not completed)

CARS complete ✓	Date	Time of Dispatch	Time Committed	Time At Scene	Time Available	Inc. #	Location Street Name	Medical Aid	MVA	Structure Fire	Vegetation Fire	Vehicle Fire	Smoke Check	Haz-Mat	Public Assist	Other (Describe)	# of Fatalities	Extrication Eqt Used	Comments: List Number of Patients as Pt x 4 If an IFT, List Destination Here Any Specific Comments, List Here
	7/1	0838	0838	0841	0849	10075	Pine St										1		Welfare check
	7/1	1056	1057	1122	1149	10083	Geysers X Sawmill Flat Rd		1										1 Pt to REACH 6 - Sutter Santa Rosa
	7/1	1323	1326		1330	10088	Washington St					1							CR
	7/1	1526	1528	1535	1622	10103	Pinewood Way		2										1 Pt to AHC ALS
	7/2	1551	1554		1601	10164	Hwy 175										2		CR
	7/3	1741	1743		1857	10232	Shenandoah Rd		3										1 Pt C2 AHC
	7/3	1858	1858		1900	10234	Hoberg Dr S			1									CR
	7/4	1846			1856	10323	S Main St, Lakeport					2							CR
	7/5	1750	1752		1930	10422	Hwy 175					3							Veg Fire
	7/5	2224	2228	2250	2322	10448	Spyglass Rd										3		NNM
	7/6	1000	1002	1010	1030	10467	Sawmill Flat @ guard shack		4										NNM
	7/6	1650	1650	1701	1729	10503	Hwy 175 mile marker 24			2									
	7/7	0040	0044	0049	0102	10522	Tee rd		5										NNM
	7/7	1421	1423	1459	1559	10554	HWY 29					4							CR
	7/8	0712	0712	0728	0833	10588	Knowles Ln		6										1 Pt C2 AHC
	7/8	1521	1521		1526	10622	RLS 2.4 N of Table Rock, Napa		7										CR
	7/9	0927	0929	0941	1052	10663	HWY 175		8										1 Pt C2 AHC
	7/9	2026	2029	2035	2046	10709	Hoberg Dr							1					UTL
	7/11	1316	1318	1340	1439	10815	seigler springs rd		9										1 Pt C2 AHC
	7/11	1439	1439	1445	1525	10821	OLYMPIC Dr		10										1 Pt C2 AHC
	7/11	2348	2351		2405	10869	St Helena Creek Rd			3									CR
	7/12	0131	0131		0133	10872	greenpoint Rd										4		CR
	7/12	1651	1651	1703	1727	10912	Dry Creek Cutoff, MT					5							Veg Fire
	7/13	1227	1227	1230	1428	10964	Ponderosa Dr					6							Propane/Veg Fire
	7/13	1650	1650	1653	1657	10983	Maple Shadows Dr		11										NNM
	7/14	0042	0042	0056	0211	10998	Loch Lomond, LL		12										1 Pt C2 AHC
	7/15	0224	0224	0238	0245	11060	Sycamore Rd										5		LA
	7/15	0828	0828	0843	1027	11068	Ridge Rd, LL		13										1Pt C2 AHC
	7/15	2108	2108		2109	11106	Calistoga St, MT			4									CR
	7/16	1320	1321	1328	1433	11142	Gifford Springs rd		14										1 Pt C2 AHC
	7/17	0951	0951	0952	1015	11201	Niblick Rd											1	C0 Detector malfunction
	7/17	1019	1021		1045	11203	S HWY 29		15										CR
	7/17	1120	1122		1130	11208	HWY 175						1						CR
	7/17	1305	1306	1317	1436	11214	Salmina Rd		16										1 Pt C2 AHC

CDF/SLCF INCIDENT TRACKING FORM

Month July 2020

Station 63

FA = False Alarm
 CR = Cancel & Return
 UTL = Unable To Locate
 AMA = Against Medical Advice
 CB = Code Blue (Full Arrest, CPR in Progress)
 LA = Lift Assist
 NMM = No Medical Merit (AMA not completed)

CA/RS complete v	Date	Time of Dispatch	Time Committed	Time At Scene	Time Available	Inc. #	Location		Medical Aid	MVA	Structure Fire	Vegetation Fire	Vehicle Fire	Smoke Check	Haz-Met	Public Assist	Other (Describe)	# of Fatalities	Extrication Eqt Used	Comments: List Number of Patients as Pt x 4 If an IFT, List Destination Here Any Specific Comments, List Here
							Street #	Street Name												
	7/1	1327	1329	CX	1331	10088		Washington St.										1		Debris Fire
	7/2	0058	0100	0104	0131	10130		Mountain Meadows		1										NMM
	7/4	0053	0055	0059	0115	10260		Hwy 29			1									Non Injury Cx by E6561
	7/4	0212	0216		0218	10263		Austin x Locust				1								Cx
	7/4	1618	1620		1623	10311		Lakeshore Dr					1							CR
	7/4	1707	1709		1713	10317		Hwy 53 #20									1			CR
	7/4	2241	2243		2251	10354		Lakeshore Dr					2							CR
	7/5	0107	0110		0124	10368		Spyglass Rd									2			Lift Assist
	7/5	2135	2137	2144	2249	10442		Big Canyon Rd / Knowles Ln		2										1 Pt C2 to AHC
	7/5	2255	2256	2258	2303	10448		Spyglass Rd									3			CR per M6211
	7/6	1209	1212	1221	1311	10476		Grange rd / Hwy 29			2									1 Pt C2 to AHC
	7/6	1648	1651	1658	1756	10503		Santa Barbra Ave. / Hwy 175			3									1 Pt C3 to Station 60 LZ
	7/7	0532	0534		0550	10529		Calistoga North			4									CR
	7/7	0636	0638	0646	0749	10531		Washington St			5									1 Pt C2 to AHC
	7/7	1508	1509	1539	1730	10558		Dam Rd					3							
	7/7	1742	1743		1748	10567		Manchester Av										2		Tree Down
	7/7	2136	2138	2145	2148	10577		Knowles Ln #6		3										CR
	7/7	2317	2319	2325	2333	10581		Park Ridge Dr			6									NMM
	7/8	0649	0653	0659	0815	10587		Greenridge Rd		4										1 Pt C2 AHC
	7/8	1008	1009	1012	1020	10600		Deer Hill Rd									4			Lift Assist
	7/8	1755	1756	1800	1903	10635		Knowlview			7									1 Pt to AHC
	7/8	2307	2308	2309	2319	10650		Spyglass Rd									5			Lift Assist
	7/9	1732	1733	1735	1750	10696		Spyglass Rd									6			Lift Assist
	7/10	1205	1207	1217	1510	10752		East Rd					4							1.5 Acres
	7/10	1806	1807	1812	1921	10772		Northshore		5										1 Pt to AHC ALS
	7/10	1923	1923		1925	10777		Hwy 53									7			Lift Assist
	7/10	1927	1927	1929	1935	10778		Spyglass Rd									8			Lift Assist
	7/10	1944	1945	1953	2006	10780		Greenridge Rd		6										Treat/Release
	7/11	0043	0046	0116	0202	10797		East Rd		7										1 Pt to AHC
	7/11	1351	1353		1420	10817		RLS			8									CR
	7/11	1455	1457	1502	1508	10825		S Hwy 29/Grange Rd							1					UTL
	7/11	2346	2350	0001	0130	10869		Saint Helena Creek		8										1 Pt w/REACH 6 to SRM
	7/12	0131	0132	CX	0140	10872		Green Point Ct.									9			Lift Assist

CDF/SLCF INCIDENT TRACKING FORM

Month July 2020

Station 63

FA = False Alarm
 CR = Cancel & Return
 UTL = Unable To Locate
 AMA = Against Medical Advice
 CB = Code Blue (Full Arrest, CPR in Progress)
 LA = Lift Assist
 NMM = No Medical Merit (AMA not completed)

CAIERS complete y	Date	Time of Dispatch	Time Committed	Time At Scene	Time Available	Inc. #	Location		Medical Aid	MVA	Structure Fire	Vegetation Fire	Vehicle Fire	Smoke Check	Haz-Met	Public Assailt	Other (Describe)	# of Fatalities	Extrication Eqt Used	Comments: List Number of Patients as Pt x 4 If an IFT, List Destination Here Any Specific Comments, List Here
							Street #	Street Name												
	7/12	1443	1445	1500	1605	10908		Rattlesnake Springs			9									1 Pt w/ Reach 6 to SRM
	7/12	1651	1653	1657	1754	10912		Dry Creek Cutoff					5							
	7/13	1049	1050	1056	1121	10957		North Shore Dr									10			NMM
	7/13	1227	1229		1243	10964		Ponderosa Dr					6							CR
	7/14	0918	0919	0922	0929	11005		Spyglass Rd		9										False call from 3rd party
	7/14	1407	1409		1417	11025		Arrowhead Rd/Country Club Dr					7							CR
	7/14	1954	1956		1959	11048		Old Hwy 53		10										CR
	7/14	2015	2017		2023	11049		Old Hwy 53 #22		11										CR
	7/14	2114	2115	2118	2144	11052		Spyglass Rd									11			Lift Assist
	7/15	1305	1307	1318	1325	11082		Kentwood Pl		12										NMM
	7/15	2108	2110	2118	2145	11106		Calistoga St			10									Non Injury
	7/16	1201	1210	1213	1235	11133		Oak Grove									12			Lift Assist - COVID19 Case
	7/16	2037	2038	2059	2120	11172		Stagecoach Cyn		13										AMR 59 Transport
	7/18	1021	1023	1031	1045	11255		Central Park Rd		14										AMA
	7/18	2004	2005	2012	2043	11302		Santa Clara Rd		15										AMA
	7/19	1011	1011	1013	1033	11338		Deer Hill rd					8							Report Submitted 7/19
	7/19	0244	0246	0256	0302	11384		Raven Hill									13			LA
	7/21	0030	0031	0040	0058	11436		Deer Hill Road			11									NMM
	7/21	0554	0556		0559	11445		Bar X Entrance Rd			12									CR
	7/21	1348	1350		1354	11467		Pine Ave		16										CR
	7/21	1550	1551	1602	1700	11476		Greenridge Rd		17										1 Pt C2 to AHC
	7/21	2112	2114	2116	2255	11498		Powder Horn Rd		18										1 Pt C2 to AHC
	7/22	1251	1252	1305	1425	11533		Powderhorn Rd		19										Transfer from AHC to RES
	7/22	1431	1432		1434	11541		Oak Grove									14			Lift Assist, Cx
	7/22	2015	2018	2029	2210	11557		Cantwell Ranch Rd					9							Veg Fire
	7/23	0732	0734	0744	0853	11636		Tinlyn Rd		20										General Illness COVID19 Confirmed
	7/24	0907	0910	0920	0950	11644		Firethorne										3		Fire Alarm Sounding
	7/24	0309				11700		Hidden Valley Rd									15			Lift Assist
	7/25	1500	1502	1512	1640	11722		Spruce Grove Rd		21										1 Pt C2 to AHC
	7/25	2146	2148		2201	11747		Santa Clara Rd		22										Cx
	7/26	0211	0214		0304	11751		Hwy 29			13									Cx
	7/26	0517	0519		0527	11756		Olympic Drive						1						Cx
	7/26	0900	0902	0932	1036	11762		Lariat St		23										AMR transport

CDF/SLCF INCIDENT TRACKING FORM

Month July 2020

Station 63

FA = False Alarm
 CR = Cancel & Return
 UTL = Unable To Locate
 AMA = Against Medical Advice
 CB = Code Blue (Full Arrest, CPR in Progress)
 LA = Lift Assist
 NMM = No Medical Merit (AMA not completed)

CAURS complete y	Date	Time of Dispatch	Time Committed	Time At Scene	Time Available	Inc. #	Location Street # Street Name	Medical Aid	MVA	Structure Fire	Vegetation Fire	Vehicle Fire	Smoke Check	Haz-Met	Public Assist	Other (Describe)	# of Fatalities	Extrication Eqt Used	Comments: List Number of Patients as Pt x 4 If an IFT, List Destination Here Any Specific Comments, List Here
	7/26	2000	2002		2004	11800	Socrates Mine Rd			14									CR
	7/26	2110	2112	2115	2229	11804	Hidden Valley Rd		24										1 Pt C2 to AHC
	7/26	2256	2258		2310	11807	Spruce Grove Rd			15									CR
	7/27	1328	1330	1342	1439	11842	Timber Point Rd		25										1 Pt C2 to AHC
	7/28	1456	1459	1530	1545	11924	Hwy 175			16									CX at scene
	7/28	1654	1656	1702	1720	11933	Meadow View Dr									16			LA
	7/30	0539	0542	0548	0655	12028	Hwy 29 X Hidden Vly Rd			17									1 Pt transferred To REACH 6
	7/30	0714	0715		0720	12029	Grange										2		Alarm Sounding Cx
	7/30	1650	1652	1659	1715	12067	Hwy 29 X Putah Ln			18									Non Injury
	7/30	2350	2352	2357	0118	12087	Northshore		26										1 Pt to AHC ALS
TOTALS:								26	18	1	9	1	1	0	16	4	0	0	
PREVIOUS:								292	53	13	6	3	5	3	33	11	1	0	
YEAR TO DATE:								318	71	14	15	4	6	3	49	15	1	0	



South Lake County Fire Protection District
— in cooperation with —
California Department of Forestry and Fire Protection

P.O. Box 1360 Middletown, CA 95461 - (707) 987-3089

DATE: August 15, 2020
TO: Board of Directors
FROM: Gloria Fong
Staff Services Analyst
SUBJECT: Resolution No. 2020-21-03, A Resolution Adopting Budget for Fiscal Year 2020-2021

For the Board's consideration is subject resolution. Following the resolution is the transmittal to County of Lake Auditor-Controller's Office. Please note it is check "yes" to allow them to adjust general reserves, as noted in resolution. The reason is final tabulation reports have not been sent out by their office yet. The reports I have are missing 50% HOPTR, 5% Teeter, final quarter interest, and final Direct Charge postings. I have estimated this to best I can to prepare adopted budget.

The increases, decreases follow. My apologies for no specific order and intended to provide an explanation of increase, decrease. These will appear on the four detailed pages following the budget summary.

Expenses

- \$1,210 annually for Target Solutions Check It App for inventorying, accountability, and transparency. This app can inventory everything from PPE to equipment and apparatus, with notification capabilities when ABC 90-day inspections are required. It also can track narcotic inventory and its movement on from location to another, avoiding possibility of misplacing paper files. Cal Fire is currently looking into utilizing this app. This is a yearly commitment with possibility of the Cal Fire paying for it in the future. Agreement addendum attached.
- \$27,062 each for three patient auto load systems for M6211, M6311, and M6011. Employees are most critical resource. Workplace injuries have a fiscal impact. While none of our injuries have been a direct result of loading patients, it is the first step in providing workplace safety. Years ago, gurneys that go up and down were purchased. With this system, platform mounted to the ambulances, it accepts and locks the gurneys in place, then slides the patient into the ambulance. Quotes attached, one for two systems and a second for one system (being revised to include sales tax).
- \$235,949 for new ambulance, M6311. The ambulance was received first week of July and its expense is incorporated into this fiscal year's budget.
- \$17,645 for pavement, seal and strip at Middletown Station 60 to prevent additional wear and damage. Three bids were received, \$23,850 from Epidendio Construction, \$33,935 from American Asphalt and \$17,645 from S&K Paving Sealing & Striping Inc.

- \$4,676 for emergency, fire escape at Hidden Valley Lake Station 63 sleeping quarters. This will be a steel emergency, fire escape. Three bids were received, \$4,676 from Weidners Welding, \$10,185 from MP Industries, and \$9,110 from Morris Welding.
- \$585 each application (\$1,170 annually) for weed eradication at Middletown Station 60. Three bids were received, \$585 each application from Armed Force Pest Control, \$1,110 each application from RB Pest Control, \$1,350 each application from Predator Pest and Weed.
- \$27,975 for SCBA bottles approved at 03/17/2020 Board meeting. Summary provided for that meeting attached. Bottles weren't available until late May early June to ship. Purchase held off with funds to be budget for their purchase this fiscal year.
- \$4,000 for Hidden Valley Lake Station 63 property survey. Survey is in preparation for expansion and includes pins and survey set. Bids were received, with one no bid from Ruzicka Associates, \$6,500 from Conser Land Surveying, and \$4,000 from Albion Surveys Inc.
- \$4,189 for Cal Fire Training Bureau. Recommended is increased to match balance being carried over.
- \$5,500 for gas monitor, calibration system (2) 36-month lease. Staff summary attached.
- \$20,000 was donated by Lake County Wine Alliance and is yet to be allocated for an expense.

Revenue

- \$937,660 increase to fund balance. Estimate is higher than that provided in recommended back in May. Reasons are \$200,000 budgeted for ambulance is carried over to this fiscal year. Increase of about \$200,000 in IGT funds (\$180k was budgeted and \$409k was receipted). The balance of about \$125k is due to receipt of supplemental property tax, disaster property tax loss relief fund, and difference between Cal Fire actual and budgeted costs. In addition, there is a return of about \$59k from Cal Fire due actual costs being less than estimated invoice for fourth quarter.
- From the aforementioned, the \$409k from IGT funds and \$25k from Redbud Health Care District is being placed into medical equipment replacement reserves along with \$544k from Assistance by Hire (ABH) funds.
- Redbud Health Care District assisted with fund the purchase of ambulance a few years ago, M6211 and the intent with this grant funding is to replenish the medical equipment replacement reserves.
- ABH is invoiced for personnel and equipment aiding in State Responsibility fires, and mutual aid (Cal OES) requests for responses to State fires. The \$544k is net from last four fiscal years.

	<u>Total</u>	<u>Equipment</u>	<u>Personnel</u>	<u>Expenses</u>	
FY 2016-17	211,391.31	143,546.20	67,845.11	9,443.52	
FY 2017-18	427,589.96	181,345.15	246,244.81	14,096.68	
FY 2018-19	318,956.30	214,767.40	104,188.90	1,189.30	
FY 2019-20	77,656.49	43,556.41	34,100.08	14,194.69	
	1,035,594.06	583,215.16	452,378.90	38,924.19	544,290.97

Property tax is increased \$10,152, an estimate based on the 55% and 40% Teeter District has already received.

Interest is increased \$25,000. This is an estimate of the final quarter interest based on higher cash balances held on deposit with the County of Lake.

Other governmental agencies is reduced by \$78,000.

Other services – fire protection is increased by \$45,000. This is based on the reports provided by the County of Lake Auditor-Controller’s direct charges division of their office.

\$321,201 in fire mitigation fee funds are transferred into operating. These funds must be expended within five years of receipt. Otherwise they are to be returned. The year before \$980 was deposited in the operating fund rather than fire mitigation fee, is carried over, applied towards the District’s share (25%) for generator project. The year before \$26,000 had been transferred in and is carried over. Funds of is transferred in for \$31,120 balance expended for generators last fiscal year, \$235,950 for ambulance and \$54,131 for two auto load systems.

Please also refer to attached that is already included when Recommended was adopted in May.

Attachments



South Lake County Fire Protection District

— in cooperation with —

California Department of Forestry and Fire Protection

P.O. Box 1360 Middletown, CA 95461 - (707) 987-3089

DATE: May 15, 2020
TO: Board of Directors
FROM: Gloria Fong
Staff Services Analyst
SUBJECT: FISCAL YEAR 2020-21 RECOMMENDED BUDGET

For the Board's consideration is the attached the Recommended Budget prepared for submission to the County Auditor-Controller's Office. Their amounts are primarily this year's adopted, adjusted based on current FY YTD and Estimated Actuals, and summary of their amounts derived from attached Budget Summary. Included for comparison only are FY 2017-18 through prior. I apologize as I had planned on a more comprehensive packet for your review. This year has been met with challenges, new accounting software, loss the front office person, and now COVID-19.

Recap:

The carryover of \$244,000 is reduced by \$150,000, IGT funds being placed into reserves. The remainder of these funds are anticipated to pay for this year's purchase of the ambulance.

Direct charges (or Measure L) is increased 2%, the estimated CPI. Please be aware the ballot didn't provide a calculation for determine how to calculate the CPI. This will be presented at the next meeting along with the Appropriations Limit resolution.

This fiscal year's property tax revenue is overstated by \$26,620. Without having to directly communicate with the County Auditor-Controller's Office, I'm assuming by the description of the posting, "CORR CS PER 2019 FY 13/14 TO 19/20, their office conducted a review of past 7 year's teeter, made adjustments in the County's favor.

With the COVID-19 shelter in place order for Lake County, our fire district offered up the ability to purchase online residential burn permits to the rest of the County. Lake Pillsbury and Northshore Fire chose to provide our online burn permit link to their residents. The impact to our fire district is minimal. This year's collection totaled about \$15,000. Prior three-year average runs about \$13,500. I anticipate the transferring about \$1,000 to neighboring fire districts before end of fiscal year.

I am projecting about \$62,000 for interest income. With our cash balance dropping due to large expenditures past few months, it is anticipated 3rd and 4th quarter's interest to come in low. The County Auditor-Controller's Office 1st and 2nd quarter postings currently total about \$47,000.

The State has provided about \$10,700 in prior year property tax loss, FY 18/19 Property Tax loss 2018 and FY 18/19 Property Tax loss 2015.

For hired equipment, mutual aid, I anticipate an additional \$30,000 provided payment is received prior to fiscal year end. In some cases, it takes between 90 to 180 days for receipt of payment. For instance, the Kincade fire from October, invoice was recently received and returned in March with payment expected May, June. This payment will cover the cost of paying our paid call firefighters in advance for their response to the Kincade fire back in October.

FY 2018-19 IGT \$268,000 contribution was met with a return of \$409,000. This is \$120,000 more than projected in adopted budget. Resolutions will be presented to move funds into reserves and appropriate a portion towards purchase of new ambulance.

Direct charges, or Measure L, collections through March total \$1,221,000. The estimated actual is expected to fall \$80,000 short from the budgeted amount. Please note this is based on prior year payment averages, payments of 22% in month April and 7% in month of May. Final collection Final collection reports won't be available until we receive the 2020-21 data late July, early August, and presented when adopted budget is presented to Board for consideration at the August meeting.

Attachments

BOARD OF DIRECTORS, SOUTH LAKE COUNTY FIRE PROTECTION DISTRICT

COUNTY OF LAKE, STATE OF CALIFORNIA

RESOLUTION NO. 2020-21 03

A RESOLUTION ADOPTING BUDGET FOR FISCAL YEAR 2020-2021

1 **WHEREAS**, the recommended budget of the South Lake County Fire Protection District has
2 been prepared and available for public review with notice published specifying the time and place of
3 the hearing for the purpose of adopting the Fiscal Year 2020-2021 Budget; and

4 **WHEREAS**, the Board of Directors held public hearing for discussion and consideration of
5 Fiscal Year 2020-2021 Final Budget; and

6 **NOW, THEREFORE**, the Board of Directors hereby resolves and directs:

7 1) The budget, as increased, modified and revised during the public hearing is hereby
8 adopted as the Fiscal Year 2020-2021 Budget for South Lake County Fire Protection
9 District, and includes appropriations for each of the object and sub-objects of the
10 expenditures listed in the Budget as amended by the Board of Directors during public
11 hearing and a memorandum of adopted budget delivered to the County of Lake Auditor-
12 Controller's Office.

13 2) The Fiscal Year 2020-2021 Budget Appropriations are summarized as follows:

14	Salaries and Benefits:	332,020
15	Services and Supplies:	3,791,196
16	Other:	100
17	Fixed Assets:	317,135
18	Contingencies:	146,937
19	<u>Reserves increase/(decrease to)</u>	<u>978,000</u>
20	TOTAL	5,565,388

21 **BE IT FURTHER RESOLVED** that the Board of Directors:

22 1) Designates Fire Chief and Secretary / Bookkeeper / Staff Services Analyst, as having
23 authority to approve budget transfers except from fixed assets or contingencies,
24 pursuant to Government Code Section 29125 (b).

25 2) Designates Fire Chief and Secretary / Bookkeeper / Staff Services Analyst, as having
26 authority to approve Inter-Fund Transfers.

27 3) Requires the number of two Board of Director signatures on all checks drawn.

28 4) Authorizes County of Lake Auditor-Controller's Office to adjust general reserve
29 designations account 357-0000-391.01-00.

30 **THIS RESOLUTION** was introduced and adopted by the Board of Directors of the South
31 Lake County Fire Protection District on the 18th day of August, 2020, by the following vote:

AYES:

NOES:

ABSENT OR NOT VOTING:

[SEAL]

SOUTH LAKE COUNTY
FIRE PROTECTION DISTRICT

MADELYN MARTINELLI
President, Board of Directors

ATTEST: _____
Gloria Fong
Clerk to the Board of Directors

COUNTY OF LAKE

MEMORANDUM

TO: Cathy Saderlund
Auditor-Controller

FROM: South Lake County Fire Protection District

SUBJECT: ADOPTED BUDGET FISCAL YEAR 2020-21

DATE: Aug-18-2020

The Board of Directors of the South Lake County Fire Prot Dist. District **DID** approve, during their public meeting on Aug-18-2020, the following for ADOPTED BUDGET and for ADOPTED RESERVES/DESIGNATIONS for fiscal year 2020-2021.

Total Appropriation for Budget Expenditures: (A) 4,587,388

Authorize Auditor-Controller to adjust Reserves/Designations as necessary

X or
YES **NO**

Increase to Reserves/Designations:

Reserve:

General 30,000

Designation:

Equipment Replacement 668,658

Building 0

Capacity Expansion 224,888

Medical Services & Supplies 762,783

Other (Identify) 2,685,445

Total Reserves/Designations (page 2): (B) 978,000

Total ADOPTED requirements for Fiscal Year 20/21 (C) 5,565,388

Authorized Signature
(Chairperson of the Board **ONLY**)

Date

For additional Budget information please contact:
Danielle Vaars Accountant-Auditor
Cathy Saderlund Auditor-Controller

ADOPTED BUDGET

Budget Summary Worksheet - ADOPTED 2020-21

(Note: Category totals on this form **must** agree with category totals of budget submission - District's responsibility).

Total Salaries & Employee Benefits	332,020
Total Service & Supplies	3,791,196
Total Other	100
Total Fixed Assets	317,135
Sub-Total	4,440,451
Total Contingencies	146,937
TOTAL APPROPRIATION FOR BUDGET EXPENDITURES	4,587,388 (A)

Increases or Decreases to Reserves/Designations - ADOPTED 2020-21

Description	Balance as of 6/30/20	(B) Increase Amount	(B) Decrease Amount	Total Budger Yr Reserves/Desgn.
Reserve:				
General	30,000	_____	_____	30,000
Designation:				
Equipment Repl	124,658	544,000	_____	668,658
Building	_____	_____	_____	0
Capacity Expansion	224,888	_____	_____	224,888
Medical Svcs/Supps	328,783	434,000	_____	762,783
Other (Identify)	2,685,445	_____	_____	2,685,445

Must be completed by District for verification by Auditor

	(A)		(B)		(C)	
Total	4587388	+	978,000	=	#####	

Total ADOPTED Appropriation \$ 4587388 (A) and total combined increase/
decrease to reserves \$ 978,000 (B) constitutes the District's Total ADOPTED
Budget financing requirement of \$ 5,565,388 (C) for Fiscal Year 2020-21.

EXPENDITURE/REVENUE SUMMARY
 INCREASES/DECREASES FROM RECOMMENDED TO ADOPTED
 FISCAL YEAR 2020-21

District Name South Lake County Fire Prot Dist Budget Unit No. 9557

Expenditures

Account #	Title	Recommended	Approved
795.17-00	Maint - Eqt	29,300	34,800
795.18-00	Maint - Bldg & Imprv	21,000	44,491
795.28-30	Spec Dpt Sup & Svc	90,611	127,985
795.62-74	Eqt - Other	-	317,135
795.90-91	Contingencies	96,955	146,937

Revenues

Account #	Title	Recommended	Approved
	Increase Reserves	(150,000)	(978,000)
411.10-10	Prop Tax Curr Sec	1,352,763	1,362,915
411.42-01	Interest	25,000	50,000
456.56-30	Oth Govt Agcy	177,080	99,080
466.69-29	Oth Svc - Fire Prot	1,682,453	1,727,922
502.81-22	Op Transf In	-	321,201
	Fund Balance	244,000	1,181,660

Advertising Order Confirmation

Ad Order Number

0006508735

Customer

SOUTH LAKE COUNTY FIRE PROTECTION DIST.

Payer Customer

SOUTH LAKE COUNTY FIRE PROTECTION DIST.

PO Number

Sales Representative

Audrey Taylor

Customer Account

3610712

Payer Account

3610712

Ordered By

Order Taker

Audrey Taylor

Customer Address

PO BOX 1360
MIDDLETOWN, CA 95461

Payer Address

PO BOX 1360
MIDDLETOWN, CA 95461

Customer Fax

Order Source

Select Source

Customer Phone

707-987-3089

Payer Phone

707-987-3089

Customer EMail

Current Queue

Ready

Invoice Text

Tear Sheets

0

Affidavits

0

Blind Box

Materials

Promo Type

Special Pricing

Advertising Order Confirmation

Lake County RECORD-BEE

08/06/20 3:47:30PM

Page 2

Ad Number
0006508735-01

Color

Production Color

Ad Attributes

Production Method
AdBooker

Production Notes

External Ad Number

Pick Up

Ad Type
Legal Liner

Released for Publication

RB20925

NOTICE OF PUBLIC HEARING

NOTICE IS HEREBY GIVEN that the Board of Directors, South Lake County Fire Protection District, has set Tuesday, Aug 18, 2020 at 7 pm to hear budget increases, modifications, and or revisions, and to adopt Resolution for Fiscal Year 2020-21 Budget. Information about attending meeting may be found at southlakecountyfire.org.

The Budget is available for inspection during normal business hours at the office of the Middletown Fire Station, 21095 Hwy 175, or at southlakecountyfire.org.

s/Gloria Fong, Clerk to the Board of Directors

8/8/2020

<u>Product</u>	<u>Requested Placement</u>	<u>Requested Position</u>	<u>Run Dates</u>	<u># Inserts</u>
Lake County Record-Bee	Legals CLS NC	Notice of Hearing NC - 1076~	08/08/20	1

Order Charges:

<u>Net Amount</u>	<u>Tax Amount</u>	<u>Total Amount</u>	<u>Payment Method</u>	<u>Payment Amount</u>	<u>Amount Due</u>
54.51	0.00	54.51	Credit Card	54.51	\$0.00

Please note: If you pay by bank card, your card statement will show "CAL NEWSPAPER ADV" or "CALIFORNIA NEWSPAPER ADVERTISING SERVICES", depending on the type of card used.

SOUTH LAKE COUNTY FIRE PROTECTION DISTRICT

BUDGET SUMMARY - SUMMARIZED

DESCRIPTION	2019-2020 <i>Est Actual</i>	2019-2020 <i>Recommended</i>	2020-2021 <i>Adopted</i>
<u>EXPENSES:</u>			
TOTAL SALARIES & WAGES	\$ 100,124.17	\$ 255,000.00	\$ 255,000.00
TOTAL BENEFITS	\$ 41,922.79	\$ 53,600.00	\$ 53,600.00
TOTAL SERVICES AND SUPPLIES	\$ 475,529.97	\$ 703,251.00	\$ 769,616.00
TOTAL CAL FIRE	\$ 2,609,230.86	\$ 3,045,000.00	\$ 3,045,000.00
PRINCIPAL, INT, NOTES & LOANS	\$ 94.29	\$ 100.00	\$ 100.00
CAPITAL OUTLAY	\$ 61,836.79	\$ -	\$ 317,135.00
<u>TOTAL EXPENDITURES</u>	<u>\$ 3,288,738.87</u>	<u>\$ 4,153,906.00</u>	<u>\$ 4,588,368.00</u>
 <u>PROGRAM REVENUES:</u>			
HOPTR (5460)	\$ 13,298.66	\$ 12,000.00	\$ 12,000.00
¹ TOTAL INTERGOVERNMENTAL	\$ 247,877.29	\$ 224,080.00	\$ 146,080.00
² TOTAL CHARGES FOR SERVICES	\$ 799,437.41	\$ 707,110.00	\$ 707,110.00
³ TOTAL OTHER REVENUE	\$ 46,819.81	\$ 44,500.00	\$ 44,500.00
⁴ TRANSFERS IN	\$ -	\$ -	\$ 322,181.00
<u>NET EXPENSE</u>	<u>(2,194,604.36)</u>	<u>(3,178,216.00)</u>	<u>(3,368,497.00)</u>
 <u>GENERAL REVENUES:</u>			
TOTAL PROP TAX SEC & UNSEC	\$ 1,456,107.21	\$ 1,376,763.00	\$ 1,386,915.00
⁶ TOTAL PROPERTY ASMT	\$ 1,693,671.86	\$ 1,682,453.00	\$ 1,727,922.00
TOTAL USE OF MONEY AND PROPERTY	\$ 62,208.15	\$ 25,000.00	\$ 50,000.00
<u>TOTAL GENERAL REVENUE</u>	<u>3,211,987.22</u>	<u>3,084,216.00</u>	<u>3,164,837.00</u>
 <u>NET SHORTFALL</u>	 <u>1,017,382.86</u>	 <u>(94,000.00)</u>	 <u>(203,660.00)</u>
 NET POSITION - BEGINNING	 \$ 164,278.07	 \$ 94,000.00	 \$ 203,660.00
 NET POSITION - END OF YEAR	 1,181,660.93	 -	 -
 <u>RESERVE DESIGNATIONS</u>			
<u>TOTAL RESERVE DESIGNATIONS</u>	<u>\$ 3,393,774.00</u>	<u>\$ 3,543,774.00</u>	<u>\$ 4,371,774.00</u>
 <u>NET POSITION - END OF YEAR</u> <i>(with reserves)</i>	 <u>4,575,434.93</u>	 <u>3,543,774.00</u>	 <u>4,371,774.00</u>

Contributions and / or Grants, i.e. pass throughs

- ¹ Gov't funds, i.e.FEMA,OES
- ² Transport,Permit & InspFee Chgs
- ³ Non-gov't'l funds, i.e.insurance proceeds,grants
- ⁴ Separate Capital Facilities Fund
- ⁶ District's voter approved asmt

Ambulance rates increase in 2013 and IFTs increa.

**SOUTH LAKE COUNTY FIRE PROTECTION DISTRICT
DETAILED BUDGET SUMMARY - EXPENSES**

ACCT #	DESCRIPTION	2019-2020								2020-2021	+ / (-)	2020-2021
		<i>Estimated Actual</i>	<i>Admin</i>	<i>Sta 60 Mdn</i>	<i>Sta 62 Cobb</i>	<i>Sta 63 HVL</i>	<i>Sta 64 LochLmd</i>	<i>FS Bldg</i>	<i>Sta 31 Amador</i>	RECOMMENDED		ADOPTED
<u>SALARIES & EMPLOYEE BENEFITS</u>												
795	1.11 SALARIES & WAGES - PERMANI	5,100.00	5,100.00							6,000.00		6,000.00
795	1.12 SALARIES & WAGES - TEMPOR	78,684.49	78,684.49							214,000.00		214,000.00
795	1.13 SALARIES & WAGES - OVERTIM	16,339.68	16,339.68							35,000.00		35,000.00
795	1.14 SALARIES & WAGES - OTHER									-		-
795	2.21 FICA/MEDICARE	7,828.05	7,828.05							10,900.00		10,900.00
795	2.22 EMPLOYEE RETIREMENT - PER									-		-
795	3.30 EMPLOYEE GROUP INSURANCE	30,581.71	30,581.71							33,900.00		33,900.00
795	3.31 UNEMPLOYMENT INSURANCE	3,513.03	3,513.03							8,800.00		8,800.00
795	4.00 WORKERS COMP	29,606.00	29,606.00							23,420.00		23,420.00
795	9.00 PAYROLL EXPENDITURE CLEAR									-		-
	TOTAL SALARIES & EMPLOYEE BENEFIT	171,652.96	171,652.96							332,020.00		332,020.00
		#VALUE!										
<u>SERVICES & SUPPLIES</u>												
795	11.00 CLOTHING & PERSONAL SUPPL	23,990.79	23,990.79							9,000.00		9,000.00
795	12.00 COMMUNICATIONS	8,297.31	3,903.57	1,527.90	1,496.35	795.22			574.27	6,700.00		6,700.00
795	13.00 FOOD	1,813.34	1,763.82		24.76	24.76				2,500.00		2,500.00
795	14.00 HOUSEHOLD EXPENSES	3,932.19		1,104.93	2,048.26	779.00				3,500.00		3,500.00
795	15.10 INSURANCE - OTHER	50,143.00		31,805.65	8,882.80	4,771.35	4,683.20			51,000.00		51,000.00
795	17.00 MAINTENANCE - EQUIPMENT	24,597.82	1,284.92	14,153.10	3,490.73	3,120.09	1,755.97		793.01	29,300.00	5,500.00	34,800.00
795	18.00 MAINTENANCE - BLDGS & IMPR	52,394.43		17,910.15	8,385.04	6,265.49	8,049.43	11,784.32		21,000.00	23,491.00	44,491.00
795	19.40 MEDICAL SUPPLIES	42,647.44	42,647.44							46,500.00		46,500.00
795	20.00 MEMBERSHIPS	1,940.00	1,940.00							6,200.00		6,200.00
795	22.70 OFFICE SUPPLIES	3,309.87		1,847.17	650.88	811.82				3,000.00		3,000.00
795	22.71 POSTAGE	621.79		428.09	34.20	159.50				620.00		620.00
795	22.72 BOOKS & PERIODICALS	-								-		-
795	23.80 PROFESSIONAL & SPECIAL SVC	2,650,040.65	2,649,140.65		180.00	180.00		540.00		3,101,900.00		3,101,900.00
795	24.00 PUBLICATIONS & LEGAL NOTIC	611.84	611.84							1,100.00		1,100.00
795	27.00 SMALL TOOLS & INSTRUMENTS	2,418.36	1,203.52	1,019.59	195.25					3,500.00		3,500.00
795	28.30 SPECIAL DEPT. - SUPPLIES & S	81,379.03	62,431.65	11,039.21	2,943.73	3,606.72	1,196.66		161.06	90,611.00	37,374.00	127,985.00
795	28.48 AMBULANCE EXPENSES	34,306.89	14,254.50	2,940.84	3,062.69	14,048.86				269,300.00		269,300.00
795	29.50 TRANSPORTATION & TRAVEL	1,822.27	1,822.27							2,000.00		2,000.00
795	30.00 UTILITIES	59,261.75		25,521.89	15,422.18	11,100.61	3,778.19	3,438.88		57,100.00		57,100.00
795	38.00 INVENTORY	11,626.06		9,071.95	1,494.13	1,059.98				20,000.00		20,000.00
	TOTAL SERVICES & SUPPLIES									3,724,831.00	66,365.00	3,791,196.00
<u>OTHER</u>												
795	42.10 PRINCIPAL, INT - NOTES & LOAI	-								-		-
795	48.00 TAXES & ASSESSMENTS	94.29		48.84	10.44	7.68	2.76	24.57		100.00		100.00

SOUTH LAKE COUNTY FIRE PROTECTION DISTRICT
DETAILED BUDGET SUMMARY - EXPENSES

ACCT #	DESCRIPTION	<u>2019-2020</u>							<u>2020-2021</u>	+ / (-)	<u>2020-2021</u>
		<i>Estimated</i>	<i>Admin</i>	<i>Sta 60 Mdn</i>	<i>Sta 62 Cobb</i>	<i>Sta 63 HVL</i>	<i>Sta 64 LochLmd</i>	<i>FS Bldg</i>	<i>Sta 31 Amador</i>		RECOMMENDED
<u>TOTAL OTHER</u>		<i>Actual</i>								100.00	100.00
<u>FIXED ASSETS</u>											
795	60.00 LAND									-	-
795	61.60 BLDG & IMPR - CURR										
795	61.69 BLDG & IMPR - PRIOR	61,836.79		19,746.37	16,622.69	15,022.46	10,445.27			-	-
795	62.71 EQUIPMENT - OFFICE									-	-
795	62.72 EQUIPMENT - AUTOS & LIGHT T									-	-
795	62.73 EQUIPMENT - SHOP									-	-
795	62.74 EQUIPMENT - OTHER									-	-
795	62.79 EQUIPMENT - PRIOR YRS									-	-
<u>TOTAL FIXED ASSETS</u>										-	317,135.00
<u>CONTINGENCIES</u>											
795	90.91 CONTINGENCIES									96,955.00	50,962.00
<u>TOTAL EXPENDITURES</u>		3,288,738.87	2,976,647.93	138,165.68	64,944.13	61,753.54	29,911.48	15,787.77	1,528.34	4,153,906.00	434,462.00
											4,588,368.00

SOUTH LAKE COUNTY FIRE PROTECTION DISTRICT
DETAILED BUDGET SUMMARY - RESERVES / REVENUE

ACCT #	DESCRIPTION	2019-2020 <i>Estimated Actual</i>	Admin	Sta 60 Mdn	Sta 62 Cobb	Sta 63 HVL	Sta 64 LochLmd	FS Bldg	Sta 31 Amador	2020-2021 <i>RECOMMENDED</i>	+ / (-)	2020-2021 <i>ADOPTED</i>
<u>GENERAL FUND - FUND 357, DEPT 955:</u>												
391	0100 RESERVES - GENERAL	30,000.00								30,000.00		30,000.00
392	0000 RESERVES - DESIGNATED (Cal	2,685,445.00								2,685,445.00		2,685,445.00
392	0400 RESERVES - EQUIPMENT REPL	124,658.00								124,658.00	544,000.00	668,658.00
392	1200 RESERVES - MEDICAL INSURAN	224,888.00								224,888.00		224,888.00
392	2500 RESERVES - MEDICAL EQT REF	328,783.00								478,783.00	284,000.00	762,783.00
	<u>RESERVES/DESIGNATIONS</u>	3,393,774.00								3,543,774.00	828,000.00	4,371,774.00
	RESERVES - (TO)/FROM	(669,830.00)								(150,000.00)	(828,000.00)	(978,000.00)
	FUND BALANCE AVAILABLE	834,108.07								244,000.00	937,660.00	1,181,660.00
	FUND BALANCE TOTAL	164,278.07								94,000.00	109,660.00	203,660.00
411	1010 PROPERTY TAX - CURR SECUR	1,382,839.93								1,352,763.00	10,152.00	1,362,915.00
411	1015 PROP 1A, ERAF/SRAF	-								-		-
411	1020 PROPERTY TAX - CURR UNSEC	24,177.15								24,000.00		24,000.00
411	1025 PROPERTY TAX - SUPP 813-CUI	45,260.73								-		-
411	1030 PROPERTY TAX - PRIOR SECUR	-								-		-
411	1035 PROPERTY TAX - SUPP 813-PRI	3,351.56								-		-
411	1040 PROPERTY TAX - PRIOR UNSEC	477.84								-		-
411	1050 PENALTIES & COSTS DELINQ T.	-								-		-
422	2160 OTH LICENSES & PERMITS	14,684.00								10,000.00		10,000.00
441	4201 INTEREST	62,208.15								25,000.00	25,000.00	50,000.00
441	4210 RENTS AND CONCESSIONS	-								-		-
453	5440 STATE DISASTER RELIEF	-								-		-
453	5460 STATE HOPTR	13,298.66								12,000.00		12,000.00
453	5470 STATE DISASTER REV LOSS	17,331.37								-		-
453	5490 STATE OTHER	110,045.50								35,000.00		35,000.00
455	5540 OTH FEDERAL DISASTER RELIE	-								-		-
456	5630 OTH GOVT AGCY	107,201.76								177,080.00	(78,000.00)	99,080.00
461	6615 MITIGATION FEES	-								-		-
461	6650 ACCTG / BANK FEES	-								-		-
465	6860 INSTNL CARE & SVC (AMB INCC	784,753.41								580,110.00		580,110.00
466	6920 OTH CURRENT SERVICES	-								117,000.00		117,000.00
466	6929 OTHER SVC - FIRE PROTECTIO	1,693,671.86								1,682,453.00	45,469.00	1,727,922.00
491	7950 REVENUE APPLICABLE PRIOR \	19,998.00								19,500.00		19,500.00
491	7970 OTH SALES - MISCELLANEOUS	1,622.50								-		-
492	7990 OTH REVENUE - MISCELLANEO	25,199.31								25,000.00		25,000.00

SOUTH LAKE COUNTY FIRE PROTECTION DISTRICT
DETAILED BUDGET SUMMARY - RESERVES / REVENUE

ACCT #	DESCRIPTION	<u>2019-2020</u> <i>Estimated Actual</i>	<i>Admin</i>	<i>Sta 60 Mdn</i>	<i>Sta 62 Cobb</i>	<i>Sta 63 HVL</i>	<i>Sta 64 LochLmd</i>	<i>FS Bldg</i>	<i>Sta 31 Amador</i>	<u>2020-2021</u>		<u>2020-2021</u>
										<i>RECOMMENDED</i>	<i>+ / (-)</i>	<i>ADOPTED</i>
492	7991 OTH REVENUE - CNCL CHECKS									-		-
492	7992 OTH REVENUE - INS REBATES									-		-
492	7993 OTH REVENUE - INS PROCEED:									-		-
502	8122 OPERATING TRANSFERS IN									-	322,181.00	322,181.00
502	8123 OPERATING TRANSFERS OUT									-		-
522	8201 NON OPERATING REVENUE											
<u>TOTAL REVENUE</u>		4,470,399.80								4,153,906.00	434,462.00	4,588,368.00
<u>TOTAL REVENUE</u> w/o Fund Balance & Re		4,306,121.73								4,059,906.00	324,802.00	4,384,708.00

Addendum

By signing the Addendum, you are 1) agreeing to the pricing and terms presented in the Agreement; 2) agreeing you have read and accept the Client Agreement and License Terms.

Date: 04-23-2020

Client Name: South Lake County Fire Protection District (CAL FIRE)	
Address: 21095 State Highway 175 (mailing: PO Box 1360) Middletown, CA 95461	
Primary Contact Name:	Primary Contact Phone:

Terms

Effective Date: Upon Return Of Signed Contract	Initial Term (months): 12	Billing Frequency: Annual	Payment Terms: Net 30
--	-------------------------------------	-------------------------------------	---------------------------------

Annual Subscription Services

Product	Description	Quantity	Unit Price	Total
TargetSolutions Check It NPP Fire Drug Safes Discount		3	\$135.00	\$405.00
TargetSolutions Check It NPP Fire Station Discount		2	\$224.00	\$448.00
TargetSolutions Check It NPP Fire Vehicle Discount		2	\$134.00	\$268.00
Total:				\$1,121.00

Grand Total (including Implementation & Training): \$1,121.00

Please note that this is not an invoice and taxes are excluded. An invoice will be sent within fourteen (14) business days of your Contract Effective Date.

IN WITNESS WHEREOF, the parties have executed this Agreement as of the last date set forth below.

TargetSolutions Learning, LLC

4890 W. Kennedy Blvd., Suite 300
Tampa, FL 33609

By: _____

Printed Name: Phil Coons

Title: Vice President, Sales

Date: _____

South Lake County Fire Protection District
(CAL Fire)

21095 State Highway 175 (mailing: PO Box 1360)
Middletown, CA 95461

By: _____

Printed Name:

Title:

Date: _____



South Lake county Power-Load x2 SS

Quote Number: 10117723
 Version: 1
 Prepared For: SOUTH LAKE COUNTY FIRE PROTECTION
 Attn:

Remit to: P.O. Box 93308
 Chicago, IL 60673-3308
 Rep: Sahel Sayfie
 Email: sahel.sayfie@stryker.com
 Phone Number: (408) 545-8169

Quote Date: 02/19/2020
 Expiration Date: 05/19/2020

Delivery Address	End User - Shipping - Billing	Bill To Account
Name: SOUTH LAKE COUNTY FIRE PROTECTION	Name: SOUTH LAKE COUNTY FIRE PROTECTION	Name: SOUTH LAKE COUNTY FIRE PROT
Account #: 1092401	Account #: 1092401	Account #: 1061716
Address: 21095 HWAY 175 MIDDLETOWN California 95461	Address: 21095 HWAY 175 MIDDLETOWN California 95461	Address: PO BOX 1360 MIDDLETOWN California 95461

Equipment Products:

#	Product	Description	Qty	Sell Price	Total
1.0	6506700001	6506 PWRLD COMPAT UPGRADE KIT	2	\$1,596.12	\$3,192.24
2.0	639005550001	MTS POWER LOAD	2	\$23,633.05	\$47,266.10
Equipment Total:					\$50,458.34

Price Totals:

Estimated Sales Tax (7.500%):	\$3,784.38
Freight/Shipping:	\$0.00
Grand Total:	\$54,242.72

Prices: In effect for 60 days.

Terms: Net 30 Days

Ask your Stryker Sales Rep about our flexible financing options.



South Lake county Power-Load x2 SS

Quote Number: 10117723
Version: 1
Prepared For: SOUTH LAKE COUNTY FIRE PROTECTION
Attn:

Remit to: P.O. Box 93308
Chicago, IL 60673-3308
Rep: Sahel Sayfie
Email: sahel.sayfie@stryker.com
Phone Number: (408) 545-8169

Quote Date: 02/19/2020
Expiration Date: 05/19/2020

AUTHORIZED CUSTOMER SIGNATURE

Deal Consummation: This is a quote and not a commitment. This quote is subject to final credit, pricing, and documentation approval. Legal documentation must be signed before your equipment can be delivered. Documentation will be provided upon completion of our review process and your selection of a payment schedule.

Confidentiality Notice: Recipient will not disclose to any third party the terms of this quote or any other information, including any pricing or discounts, offered to be provided by Stryker to Recipient in connection with this quote, without Stryker's prior written approval, except as may be requested by law or by lawful order of any applicable government agency.

Terms: Net 30 days. FOB origin. A copy of Stryker Medical's standard terms and conditions can be obtained by calling Stryker Medical's Customer Service at 1-800-Stryker.

In the event of any conflict between Stryker Medical's Standard Terms and Conditions and any other terms and conditions, as may be included in any purchase order or purchase contract, Stryker's terms and conditions shall govern.

Cancellation and Return Policy: In the event of damaged or defective shipments, please notify Stryker within 30 days and we will remedy the situation. Cancellation of orders must be received 30 days prior to the agreed upon delivery date. If the order is cancelled within the 30 day window, a fee of 25% of the total purchase order price and return shipping charges will apply.

Re: Quote and Stryker PO

Segovia, Sahel

Wed 8/12/2020 12:08 PM

Warning: this message is from an external user and should be treated with caution.

Hi Gloria,

Yes my quote did not include sales tax but it will be added once you receive your invoice. Let me know if there is anything else I can assist with!

Best,

Sahel Segovia
Emergency Care Sales Manager
11811 Willows Rd NE
Redmond, WA 98052
strykeremergencycare.com

From: Fong, Gloria>
Sent: Wednesday, August 12, 2020 12:03:38 PM
Subject: RE: Quote and Stryker PO

EXTERNAL EMAIL

I didn't see 7.25% sales tax on the quote and want to confirm it will be added.

Gloria Fong

Staff Services Analyst
South Lake County Fire Protection District

CAL FIRE

Bus: (707) 987-3089

Fax: (707) 987-9478

From: Segovia, Sahel
Sent: Monday, August 10, 2020 9:46 AM
Subject: RE: Quote and Stryker PO

Warning: this message is from an external user and should be treated with caution.

Hi Chief,

Awesome, you guys don't need a new floor plate so I will go ahead and take that off of your quote and process it. Thanks for letting me know!

Best,

Sahel Segovia
Emergency Care Sales Manager
11811 Willows Rd NE
Redmond, WA 98052
strykeremergencycare.com



Estimate & Contract

Name: South Lake County Fire Protection District
Attention: Tyler or Tony
Phone: 805-835-6370 or 987-2953
Fax:
Email: anthony.dozier@fire.ca.gov

Date: 1-5-20
Job Number: 3002-20
Job Name: Parking Lot
Job Address: 21095 St Hwy 175
Middletown, CA 95461

We propose to furnish labor and material in strict accordance with the plans and/or specifications as follows:

- SEALER: To clean all debris and apply 2 coats of Steel Guard 60 pavement sealer on 35,687 sq.ft. of asphalt.
(Sealer has 2% Latex added to it for extra strength.) = \$13,560.00
- CRACKS: Clean out cracks if needed for sealant to adhere to. Inject Crafc0's Super Flex To cracks over 1/4" or bigger at 380 degrees application temperature and sand on top of crack fill.
Approximate Total Lineal Feet of Cracks = 3,000 Feet = \$3,000.00
- STRIPES: 55 Stripes, 2 handicap and 1-8' hash area. = \$1,085.00

To be paid in full when work is complete.

TOTAL = \$17,645.00

Section I: Instrument as Entire Agreement

This instrument contains the entire agreement between the parties, and no statements, promises or inducements made by either party or agent of either party that are not contained in this contract shall be valid or binding; this contract may not be enlarged, modified or altered except in writing signed by both parties and endorsed on this agreement. Any alterations or deviations from the above mentioned specifications involving extra costs, will be executed only upon written change orders, and will become an extra charge over and above the estimate. S+K also agrees to provide performance bonds and payment bonds as may be requested by the Owner. The fee for such bonds will be at the Owner's expense and will be over and above the estimate. S+K will not be held liable for any damage resulting from existing conditions and/or damage to our scope of work caused by conditions or forces beyond our control. Prior to commencement of work, all clearing of shrubs, trees, plants, and preparation (beyond our scope of work) is to be completed by owner of property. All warranties on labor are for a period of one (1 year) after one (1 year) all labor is subject to the current labor pricing dictated by S+K. No other warranty is made, expressed or implied. Estimates are good for 30 days only.

Section II: Effect of Agreement

I HERE BY HAVE READ THE ABOVE AND AGREE TO ABIDE BY ALL THE TERMS OF THIS CONTRACT.

Signature of S & K Representative _____ Date _____

Signature of Property Representative Anthony Dozier FAE/P Date 4/14/20

EMAIL: sandkseal@frontiernet.net

1278 Craig Ave. Lakeport, CA 95453- Phone (707) 279-9555 Fax (530) 549-3820

Proposal

EPIDENDIO CONSTRUCTION, Inc.

P.O. Box 452
Lower Lake, California 95457
(707) 994-5100 License #637395
FAX (707) 994-7030

Proposal Submitted To:	Phone	Date
South Lake Fire Dept. Attn: Kevin S.	707-987-2953	June 5, 2020
Street	Job Name	
P.O. Box 1360	Crack Filling and Seal Coating of Lot	
City, State and Zip Code	Job Location	
Middletown, CA 95461	21095 Hwy 175, Middletown	
E-Mail Address	Date Of Plans	Job Site Phone
Kevin.Seymour@fire.ca.gov	N/A	707-987-2953

We hereby submit specifications and estimates for the following:

1) Parking lot rehab (Crack Filling and Seal Coating)

- a) Clean, sweep and wash existing Asphalt surfaces totaling ~ 35,000 Sf.
- b) Provide and apply rubberized crack filler throughout cracks larger than 1/2" wide x ~ 3,500 Sf.
- c) Provide and apply Double application of OverKote sealcoat throughout asphalt surface(s) totaling 35,000 Sf.
- d) Provide and apply striping throughout lot per the existing layout.

Bid: \$23,850

Notes:

Area is to be free from all vehicular and pedestrian traffic. All parked vehicles are to be relocated to West lot for the duration of the project. Project includes crack filling of approximately 3,500 Lf of 1/2" wide cracks. During the course of work, additional crack filling may be required above the included 3,500 Lf; additional costs may incur. Water is to be available for use to fill our water truck(s) during the course of work. Due to the failing condition in some asphalt sections, seal coat may crack or flack. Any and all repairs are excluded. Any and all asphalt repair / patch work is excluded. Bid price is based upon the above scope of work and quantities, any variation(s) to the above will be billed on a time and material basis. Striping is to be replaced in kind with the existing. Excludes painting / striping of curbs stops or concrete curbs. Excludes replacement of any and all signage. Bid price excludes prevailing wage.

Excludes: SURVEY, PERMITS, EROSION CONTROL, FEES, TESTING & INSPECTION

We Propose

hereby to furnish, material and labor - complete in accordance with above specifications, for the sum of:

Twenty Three Thousand Eight Hundred Fifty Dollars & Zero Cents.

Payment to be made as follows:

IN FULL UPON COMPLETION OF WORK

All material is guaranteed to be as specified. All work to be completed in a workmanlike manner according to standard practices. Any alteration or deviation from above specifications involving extra costs will be executed only upon written orders, and will become an extra charge over and above the estimate. All agreements contingent upon strikes, accidents or delays beyond our control. Owner to carry fire, tornado and other necessary insurance. Our workers are fully covered by Workman's Compensation Insurance.

Authorized
Signature _____

Note: This proposal may be
withdrawn by us if not accepted within: THIRTY (30) days

Acceptance of Proposal

The above prices, specifications and conditions are satisfactory and are hereby accepted. You are authorized to do the work specified. Payment will be made as outlined above.

Signature: _____

Date of acceptance: _____

Signature: _____

24200 Clawiter Road
P.O. Box 3367
Hayward, CA 94540



Tel: (510) 723-0280
Fax: (510) 723-0288
License No. 439591

Date: 5/28/2020

American Asphalt
Repair & Resurfacing Co., Inc.

Estimator: Stu Miller
Cell: (707) 732-0274
smiller@americanasphalt.com

Proposal #: PR-19464

Proposal & Contract

Billing Address: Fire Apparatus Engineer-Paramedic Hidden Valley Station 63 Kevin Seymour Hwy 175 Middle Town, CA 95461 tony.dozler@fire.ca.gov Phone:(707) 987-2953	Property Address: 21095 Hwy 175 Middle Town, CA 95461 Project Name: Hidden Valley Fire Station 63 2020 Slurry
--	---

Sq Ft.	Scope of Work	Unit	Total
36840	Clean thoroughly entire area using either power broom or power blowers, clean and treat all oil spots with 'poly-oil seal', mask all utility boxes, monuments, manholes and covers and resurface with Slurry Surfacing Type II using crushed Black Volcanic Aggregate and MICRO Emulsion in accordance with Cal Trans Specification 37-3.	L/S	\$27,850.00
	Clean and prepare by any method necessary, all cracks wider than 1/4" and install hot rubberized asphalt crack-filler per manufacturer's specification.	L/S	\$4,300.00
	Re-stripe entire complex back to existing layout. Using 1 coat of oil based traffic paint.	L/S	\$1,785.00
Total Bid			\$33,935.00

PAYMENT TO BE MADE AS FOLLOWS: **NET UPON COMPLETION**

As a California Contractor, work is warranted against failure due to poor workmanship or faulty material, for a period of 1 year. However, we will offer a **THREE-YEAR WARRANTY** provided payment is made per terms. Non-payment per terms voids the extended warranty.

ACCEPTANCE OF PROPOSAL All the terms and conditions set forth on the reverse side of this Proposal and Contract are incorporated herein by reference and have been read and understood by the undersigned. The above prices, specifications and conditions are satisfactory and are hereby accepted. You are authorized to do the work as specified. Prices quoted are valid for 30 days.

Authorized Customer Signature Date

American Asphalt Signature Date

1. As part of this contract, American Asphalt R&R Co., Inc., is the "Contractor" and the client listed is the "Owner."
2. **NOTICE TO OWNER:** (Section 7019-Contractors License Law): under the Mechanic's Lien Law, any contractor, subcontractor, laborer, materialman or other person who helps to improve your property and is not paid for his labor, services or material, has a right to enforce his claim against your property. "Under the law you may protect yourself against such claims by filing, before such work or improvement, an original contract for the work or improvement or a modification thereof, in the office of the county recorder of the county where the property is situated and requiring that a contractor's payment bond be recorded in such office. Said bond shall be in amount not less than fifty percent (50%) of the contract price and shall, in addition to any conditions for the performance of the contract, be conditioned for the payment in full of the claims of all persons furnishing labor, services, equipment or materials for the work described in said contract. Contractors are required by law to be licensed and regulated by the Contractor's State License Board. Any questions concerning a contractor may be referred to the registrar, Contractor's State License Board, 3132 Bradshaw Road, Sacramento, CA. Mailing address: P.O. Box 26000, Sacramento, CA 95826.
3. Your attention is directed to sections 3097, 3098 and 3111, California Civil Code which requires us to notify you by way of a California Preliminary Notice "that if bills are not paid in full for labor, services, equipment or materials furnished, or to be furnished, the improved property (which is described hereon) may be subject to liens." This statement is applicable to private work only. This is not a reflection on the integrity of you or any contractor or subcontractor.
4. **CHANGES IN WORK SCOPE:** Owner may not require Contractor to perform extra or change-order without providing written authorization prior to the commencement of work covered by the new change order. A Change Order, relative to specific change order work, shall be incorporated into the Contract and shall become part of Contract only if it is in writing and signed by the Parties prior to the commencement of any work covered by the Change Order. Each Change Order shall be subject to the terms and provisions of the Contract.
5. **HIDDEN CONDITIONS:** The Contractor shall not be obligated to perform any work to correct damage caused by any hidden conditions including, but not limited to, unknown subsurface conditions, code upgrades, unforeseen construction deficiencies, etc. unless expressly included in the written specifications of Work.
6. The Contractor, at its own cost and expense, shall procure and maintain during the continuance of this contract, a policy of worker's compensation or employer's liability insurance for protection of the employees, including executive, managerial and supervisorial employees, engaged in work on the project.
7. **OWNER RESPONSIBILITIES:** Owner will point out and warrant the property lines to Contractor; Owner shall take all responsibility for entering and being on Project being worked upon by Contractor during the course of Project; Owner will be responsible for obtaining permission, whenever and wherever necessary during the course of Project, from the appropriate parties or authorities with respect to performing operations on or from adjoining properties.
8. At owner's own cost and expense, shall procure promptly after execution of this contract, and maintain during the continuance of this contract, a policy of fire insurance with course of construction, vandalism, and malicious mischief clauses attached, insuring the project and all materials delivered to the site of the project, for their full insurable value, with loss thereunder payable to owner and Contractor as their interest may appear.
9. **LATE PAYMENTS:** If Owner fails to make payments to Contractor in accordance with the Contract, Owner agrees to pay Contractor a late charge equal to the rate of 1 1/2% per mo. Or 18% per annum on such payments owing until paid.
10. **PERMIT FEES, TAXES:** Unless otherwise provided in the Contract, Owner shall reimburse Contractor for all sales taxes which are legally enacted on the date of the Contract, any permits, and any inspections necessary for the proper execution and completion of Work.
11. **ADA:** Contractor is not a certified ADA consultant and makes no representation regarding whether any portion of the Work is in compliance with the ADA. Contractor recommends that Owner engage an ADA consultant to evaluate all planned work for ADA compliance. Owner agrees that Contractor shall have no responsibility for ADA compliance relating to its work.
12. **INDEMNIFICATION:** To the extent caused by the willful misconduct and active or sole negligence of Contractor, or Contractor's agents or independent contractor, Contractor shall indemnify, defend, release and hold harmless Owner from and against all claims, demands or liabilities for damages, losses or expenses, including but not limited to attorneys' and consultants' fees, costs and expenses, arising out of Contractor's work on the Project and resulting in death or bodily injury, injury to property, tangible or otherwise, including the loss of use resulting therefrom, other than Project itself.

Unless caused by Contractor's active or sole negligence or willful misconduct, Owner shall indemnify, defend, release and hold harmless Contractor, Contractor's employees, agents, and independent contractors who are directly responsible to Contractor from and against all claims, demands or liability for damages, losses or expenses, including but not limited to attorneys' and consultants fees, costs and expenses, arising out of or encountered in connection with the Project to such extent as not in contradiction of the preceding paragraph pertaining to the indemnity obligations of Contractor.

The obligations of Owner and Contractor under this Paragraph entitled "Indemnification" shall not be limited by any limitation on amount or type of damages, compensation or benefits payable by or for Contractor or subcontractors under workers' compensation acts, disability benefit acts or other employee benefits, insurance required under the Paragraph entitled "INSURANCE", or whether the matters as to which the indemnification apply arise during the course of or after completion of Project and shall apply regardless of Contractor's or Owner's breach of the Contract, and nothing shall be deemed to abridge the rights, if any, of Owner and Contractor seek contributions where appropriate and shall extend to matters occurring and/or arising after completion of Project and/or the termination and/or conclusion of the Contract, as well as during the indemnity, hold harmless, defense and release provided to Contractor, in any term or provision of the Contract, is not to the exclusion or prohibition of any other remedy or course of action as all such remedies are cumulative and are separately and individually, as well as jointly enforceable.
13. **WARRANTY:** For a period of one year following the date of substantial completion of Work, Contractor guarantees the Work against original defects of material and workmanship and agrees to mitigate, at its own cost, any Work which does not conform to the Contract or meet the standards of the industry, and remedy any defects resulting from faulty materials or workmanship which become evident, excluding any changes caused by normal settling and shrinkage. However, we will offer a three year warranty provided payment is made per terms. Non-payment per terms voids the extended warranty.

If set out in the Contract, Contractor agrees to sealcoat the asphalt pavement with the product specified herein. The sealcoat product used will meet or exceed the specification. The intended use of sealcoating materials is to resurface existing asphalt pavements and is not intended to restore badly cracked or broken base pavement nor permanently seal cracks subject to base movement. Cracks sealed or filled may open again.

Contractor is not liable for cracks which will occur in the new pavement surface due to earth movement, soil expansion, soil contraction or tree roots. This applies to all new asphalt and concrete surfaces.
14. **VENUE:** In the event of the commencement of legal proceedings alleging violations of the terms of the Contract, Alameda County, California shall be deemed the appropriate venue (unless Project is located in another County in which event that County shall be appropriate for the enforcement of mechanic lien rights) for the litigation due to, but not limited to, the fact that payment to Contractor is to be made in Alameda County, California and/or this the Contract is deemed to have been entered into in Alameda County, California.
15. **DISPUTES:** If either party becomes involved in any litigation arising from or relating to this contract or the performance of it, the prevailing party shall be entitled to recover its reasonable attorney's fees and costs, including expert witness fees.
16. **TIME OF THE ESSENCE:** All time limits stated in this contract are of the essence to this contract, and failure to comply with this provision shall be a material breach of this contract. Unless otherwise expressly stated, all references in this contract to days mean calendar days.

Weidners Welding

LIC # 1036454

(707) - 530 - 1349

Proposal of Work

Proposal Submitted To <i>Hidden Valley Fire</i>	Date <i>4-9-20</i>
Address, City, State, Zip	Job Description <i>escape ladder</i>

We propose to provide all materials and labor necessary for the completion of the following:

<p><i>160' 2x2x 1/2 Square Tube - 700.00</i></p> <p><i>20' 3/16 x 4 Flat Bar - 60.00</i></p> <p><i>16 sq Ft #3 expanded Grating - 300.00</i></p> <p><i>11 - 24" LATCH HINGES - 396.00</i></p> <p><i>PAINT and accessories - 150.00</i></p> <p><i>Self closing hinges - 200.00</i></p> <p><i>Material for door - 300.00</i></p> <p style="text-align: center;"><i>MATERIAL TOTAL - 2,196.00</i></p> <p style="text-align: center;"><i>LABOR WELDING / FABRICATING, PAINTING and FASTENING</i></p> <p style="text-align: center;"><i>FIRE ESCAPE LADDER 2,500.00</i></p> <p style="text-align: right;">Total Cost: <i>4,696.00</i></p>

Authorized Signature: _____

Date: _____

ACCEPTANCE OF PROPOSAL: The above prices, specifications, and conditions are satisfactory and hereby accepted. You are authorized to do the work as specified. Payment will be made as outlined above.

Signature: _____

Date: _____



MP Industries, Inc.
 13733 W Rena Dr
 LARGO, FL 33771 US
 (888) 858-6368
 www.industrialmaintenanceplatforms.com

Estimate

ADDRESS

Dennis Lange (707) 987-2953
 CAL FIRE California Department of
 Forestry and Fire Protection
 Dennis.T.Lange@fire.ca.gov

SHIP TO

CAL FIRE California Department of
 Forestry and Fire Protection
 Unit - Station 63
 19287 Hartman Rd.
 Middletown, CA 95461

ESTIMATE #	DATE	EXPIRATION DATE
16225	04/01/2020	05/01/2020

SHIP VIA
 Included

SALES REP
 JB-KC

QTY	MODEL #	DESCRIPTION	RATE	AMOUNT
1	F12S-LDG-SP	Custom steel fire escape ladder and landing **Per attached approved drawing Platform size: 144" H x 48" W x 48" L. Traction tread rungs, 22.5" W, spaced at 12". Expanded metal platform grating. Square tube railing: 42" H w/21" mid-rails and 4" kick plates. 24" wide walk-through at ladder location. 300 lb. capacity. Carbon steel construction Gray powder coat finish. Includes upper mounted security panel with spring loaded hinges and latch bolt. Latch is mounted on the platform facing side for quick access from landing during egress. Fully welded ladder and landing construction. Ladder standoffs, foot plates, and landing rear face are drilled to accept 1/2" anchors (not included). OSHA and ANSI compliant design.	7,305.00	7,305.00
1	Freight	Shipping to: Department of Forestry and Fire Protection CAL FIRE Sonoma Lake Napa Unit - Station 63 19287 Hartman Rd. Middletown, CA 95461 **Includes packaging and delivery. **Subject to change based on rates at time of purchase/shipping	2,880.00	2,880.00

- Service Disabled Veteran Owned Small Business (S.D.V.O.S.B) -- Cage Code: 6C9K5 -- Duns# 967917068

- First time customers pay up front. Please advise your representative on method of payment.

- All custom orders and orders over \$5,000.00 require a 50% deposit, with balance due prior to shipment.

- Convenience and processing fees when paying with a credit card may apply.

- All custom orders and cantilever ladders are non-returnable and nonrefundable.

*** Freight quotes valid for 30 days only and are estimated and subject to change.

*** Lead-times are estimated and subject to change without notice, if there is an immediate need please inquire about expedited services.

TOTAL

\$10,185.00

Accepted By

Accepted Date

11210 Socrates Mine Road
P.O. Box 567
Middletown, CA 94567
Phone (707) 987-1114
Fax (707) 987-1110
sonnie@morrisweldingco.com



Project: South Lake County Fire

Contractor: N/A

Date: 5-20-2020

We have reviewed your request for pricing fabricating a fire escape ladder with landing and security door. Pricing is based off the design provided; material sizes have been assumed. We have provided pricing for the ladder to be either powder coated (basic color) or galvanized. I have also given pricing for the ladder to FOB (fabricated and delivered installed by others) or furnished and installed by us. Price excludes prepping building for attachment of ladder or providing a footing to support ladder.

Total Cost:	FOB	Furnished and Installed
Powder Coated	\$7,075.00	\$9,200.00
Hot Dip Galvanized	\$6,985.00	\$9,110.00

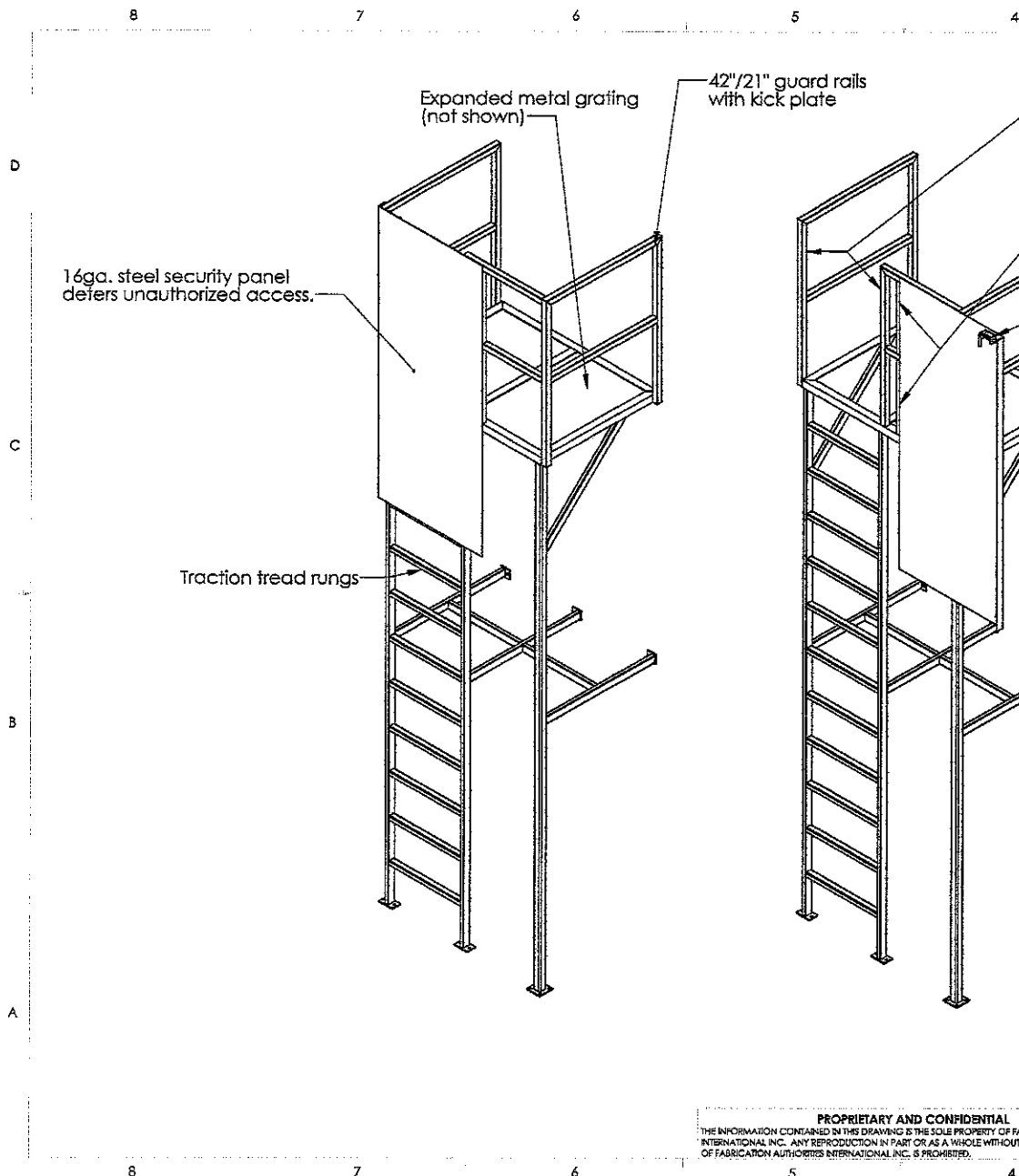

16ga. steel security panel defers unauthorized access.

Expanded metal grating (not shown)

42"/21" guard rails with kick plate

square tube railings are unobstructed for use as grab bars when exiting the landing onto the ladder.

Self-opening spring hinges hold the security panel open for safe egress when ladder is in use.

Latch bolt with spring holds gate shut, accessible from top level only.

Traction tread rungs

NOTES:
 THE MODEL SHOWN IN THIS DRAWING IS STEEL. MATERIAL SIZES WILL VARY IN ALUMINUM.
 CAPACITY: 300 LBS.
 PLATFORM: 3# EXPANDED METAL GRATING.
 RUNGS: TRACTION TREAD 3 HOLE LADDER RUNG.
 MATERIAL: STEEL/ ALUMINUM.
 FINISH: GALVANIZED OR POWDERCOATING (STEEL), MILL FINISH (ALUMINUM).
 CLIENT REF: DENNIS LANGE.

FABRICATION AUTHORITIES INTERNATIONAL
 13733 W RENA DR, SUITE C
 CLEARWATER, FL 33771
 PHONE (844) 727-8263 FAX (888) 909-6780

UNLESS OTHERWISE SPECIFIED:
 DIMENSIONS ARE IN INCHES
 TOLERANCES:
 FRACTIONAL: ±1/16"
 ANGULAR: MACH ±1° BEND ±1°
 TWO PLACE DECIMAL ±0.01
 THREE PLACE DECIMAL ±0.005
 INTERPRET GEOMETRIC TOLERANCING PER: ANSI Y 14.5M-1994
 MATERIAL: see notes
 FINISH: see notes
 DO NOT SCALE DRAWING

NAME	DATE	JOB NUMBER:
JB	2/4/2020	
DRAWN	CHECKED	TITLE:
ENG APPR.	ENG APPR.	Dennis Lange- custom fire escape ladder with landing
MFG APPR.	MFG APPR.	SIZE DWG. NO.
Q.A.	Q.A.	REV
THIRD ANGLE PROJECTION		Dennis Lange- custom fire escape ladder with landing
		SCALE: 1:24 WEIGHT: 267 SHEET 1 OF 2

PROPRIETARY AND CONFIDENTIAL
 THE INFORMATION CONTAINED IN THIS DRAWING IS THE SOLE PROPERTY OF FABRICATION AUTHORITIES INTERNATIONAL INC. ANY REPRODUCTION IN PART OR AS A WHOLE WITHOUT THE WRITTEN PERMISSION OF FABRICATION AUTHORITIES INTERNATIONAL INC. IS PROHIBITED.

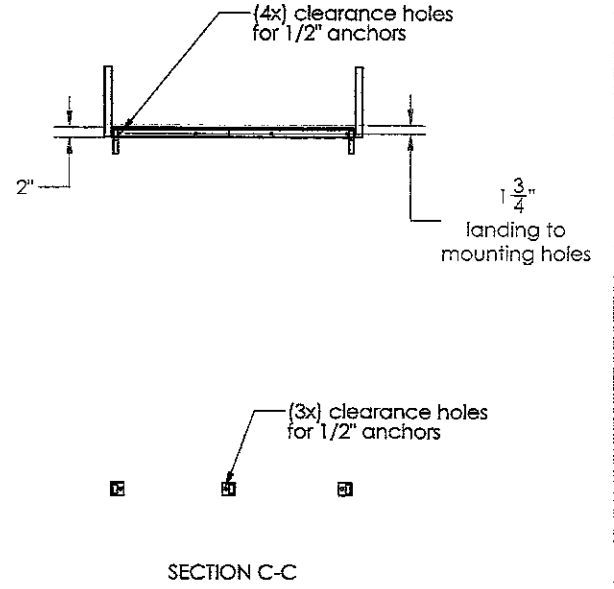
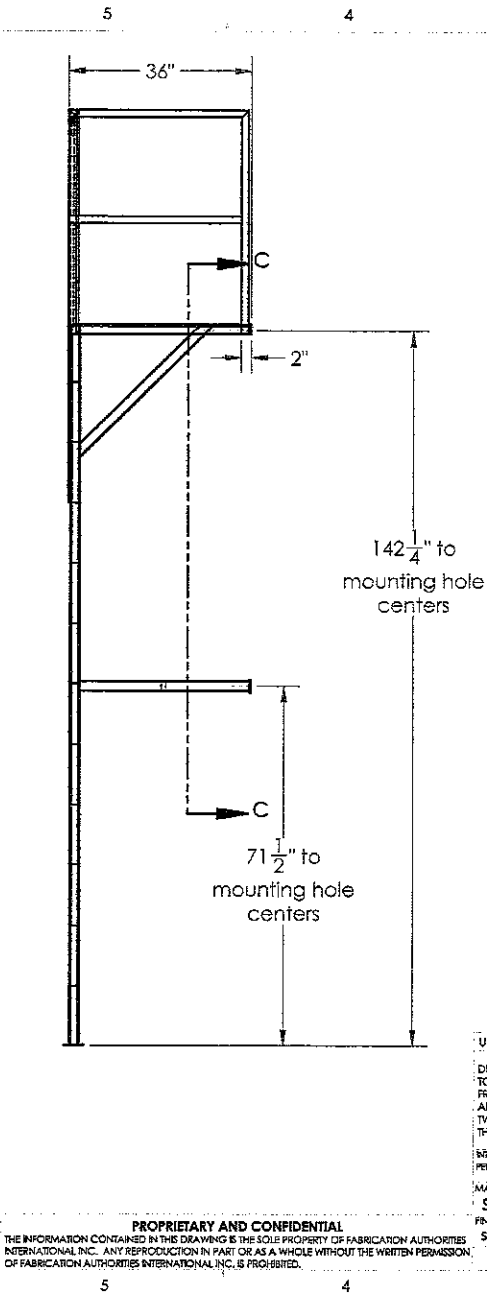
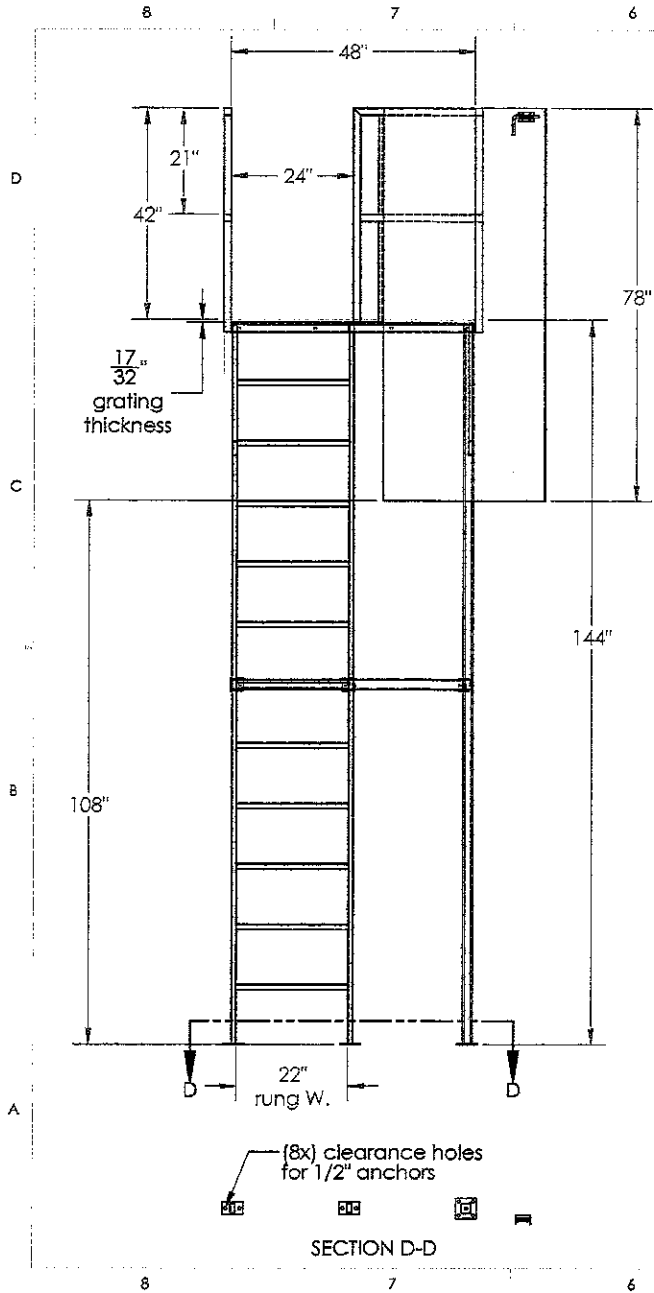

PROPRIETARY AND CONFIDENTIAL
 THE INFORMATION CONTAINED IN THIS DRAWING IS THE SOLE PROPERTY OF FABRICATION AUTHORITIES INTERNATIONAL, INC. ANY REPRODUCTION IN PART OR AS A WHOLE WITHOUT THE WRITTEN PERMISSION OF FABRICATION AUTHORITIES INTERNATIONAL, INC. IS PROHIBITED.

UNLESS OTHERWISE SPECIFIED: DIMENSIONS ARE IN INCHES TOLERANCES: FRACTIONAL: ±1/32" ANGULAR: MACH ±1° BEND ±1° TWO PLACE DECIMAL: ±0.01 THREE PLACE DECIMAL: ±0.005 INTERPRET GEOMETRIC TOLERANCING PER: ANSI Y 14.5M-1994	DRAWN CHECKED ENG APPR. MFG APPR. Q.A. THIRD ANGLE PROJECTION	NAME JB	DATE 2/4/2020
MATERIAL see notes	FINISH see notes	JOB NUMBER:	
DO NOT SCALE DRAWING		TITLE: Dennis Lange- custom fire escape ladder with landing	

FABRICATION AUTHORITIES INTERNATIONAL
 13733 W RENA DR, SUITE C
 CLEARWATER, FL 33771
 PHONE (844) 727-8263 FAX (888) 909-6780

SIZE DWG. NO. **B**

REV **A**

SCALE: 1:24 WEIGHT: 267 SHEET 2 OF 2



SERVICE AGREEMENT

Armed Force Pest Control, Inc
 18255 Vintage Ct Suite D
 Middletown, CA 95461
 (707)987-9828 | info@armedforcepest.com
 License #: PR4227

Service Address

SOUTH LAKE FIRE DISTRICT
 21095 Hwy 175
 MIDDLETOWN, CA 95461

Customer Information

(707)987-3089 |

Notes: Service to be completed twice per year, early Spring and early Fall using pre-emergent, post-emergent & surfactant materials. 90% coverage is guaranteed and re-treatments between regular services are included and will not be charged any additional fees. Areas included are areas 1-9, as described in the proposal packet, with areas 7-9 being perimeter & crack & crevice treatments. *Please note that it typically takes 2-3 weeks for weeds to START dying post treatment. We are happy to re-treat and touch up any missed areas after the initial 2-3 weeks post treatment.

Included Insects

WEEDS

Year Round Pest Barriers

Weeds are best controlled when treatments are completed twice per year, Spring & Fall. Ideal treatment conditions are dry weather when the treatment takes place with rain following within two weeks. If it does not rain within two weeks from your weed spraying service, please lightly water the treated areas with your garden hose for optimal results.

Weeds Subscription

May '20	Jun '20	Jul '20	Aug '20	Sep '20	Oct '20
(S)585.00					
Nov '20	Dec '20	Jan '21	Feb '21	Mar '21	Apr '21
(S)585.00					

Initial Service / Warranties

Initial Quote: \$585.00
 Initial Discount: (\$0.00)
 Sub Total: \$585.00
 Tax (0%): \$0.00
 Initial Total: \$585.00

Recurring Services

Service Charge: \$585.00
 Tax (0%): \$0.00
 Recurring Total: \$585.00

Unless the service agreement states otherwise, it is understood and agreed that this contract shall be for a period of one year from the above date, and shall continue thereafter month to month until the agreement is canceled in writing. The Armed Force Pest Control agrees to provide pest control services in accordance with the terms outlined plus any additional services as may be deemed necessary by The Armed Force Pest Control, or as requested by you. In order to properly control pest activity, the customer agrees to make premises available for service and to accept such service when it is due. Your technician will make an appointment for the initial service, and when appropriate, will arrange to notify you prior to future services. All equipment used on the premises remains the property of The Armed Force Pest Control and may be removed upon termination of service. While the intent of this service is to prevent damage from pests, The Armed Force Pest Control shall not be liable if such damage should occur during the period such service is rendered. If this contract is cancelled before the end of one year, there will be a cancellation fee due at a rate of 30% of any un-billed services or one service, whichever is greater. If the fees remain unpaid for a period of 60 days, the customer's account will be placed with a collection agency of The Armed Force Pest Control's choice until paid. The customer will be responsible for paying any costs associated with the collection of fees. Credit cards kept on file will be charged after services are completed and until the payment processes. You authorize Armed Force Pest Control to apply charges to your credit card for services, missed or skipped services, late fees, returned check fees, and early cancellation fees.

Billing Info

SOUTH LAKE FIRE DISTRICT HIDDEN VALLEY STATION
 PO BOX 1360
 MIDDLETOWN, CA 95461

Payment Information

SOUTH LAKE FIRE DISTRICT
 HIDDEN VALLEY STATION
 I authorize Armed Force Pest Control, Inc to automatically bill my debit/credit card upon completion of each service.

Dear Customer:

Thank you for selecting Armed Force Pest Control, Inc. to perform your pesticide & herbicide application requirements. In accordance with the laws and regulations of The State of California, we are required to provide you with the following information prior to application of chemicals to your property. Please take a few moments to read and become familiar with the content.

State law requires that you be given the following information: CAUTION-PESTICIDES ARE TOXIC CHEMICALS. Structural Pest Control Companies are registered and regulated by the Structural Pest Control Board, and apply pesticides which are registered and approved for use by the Department of Pesticide Regulation and the United States Environmental Protection Agency. Registration is granted when the state finds that, based on existing scientific evidence, there are no appreciable risks if proper use conditions are followed or that the risks are outweighed by the benefits. The degree of risk depends upon the degree of exposure, so exposure should be minimized.

If within 24 hours following application you experience symptoms similar to common seasonal illness comparable to the flu, contact your physician or poison control center (800-222-1222) and your pest control company immediately. If rodenticide ingestion occurs, you may experience flu-like symptoms as well as difficulty breathing, weakness, lethargy or excessive bleeding and you should contact your physician or poison control center (800-222-1222) and your pest control company immediately.

For further information contact any of the following:

Armed Force Pest Control, Inc. (Lake County): 707-987-9828 Fax: 707-987-9829

Statewide Poison Control Center: 800-222-2222

County Agriculture Commission (Application Information): Lake County: 707-263-0217 / Sonoma County: 707-565-2371

Mendocino County: 707-234-6830 / Napa County: 707-253-4357

County Health Department (Health Questions): Lake County: 707-263-8929 / Sonoma County: 707-565-4700

Mendocino County: 707-456-3800 / Napa County: 707-253-4279

Structural Pest Control Board (Regulatory Information): 916-561-8708 2005 Evergreen Street, Ste. 1500 Sacramento, CA 95815

Department of Pesticide Regulation (Regulatory Information): (916) 445-4038 1001 I Street, Sacramento, CA 95814

GUARANTEE: Armed Force Pest Control recommends Monthly or Bi-monthly maintenance services to control most of your pest control problems, and we guarantee all of our service agreement. We want to help you control your pest problems, so should you have any questions or concerns, please do not hesitate to call us. While the purpose of this service is to prevent damage from pests, Armed Force Pest Control, Inc. cannot be held liable if such damage or infestation should occur during the period of this contract. It is expressly stipulated and agreed that the company shall not be liable for any delays occasioned by the elements, strikes, fire, and inclemency of weather, the acts of omissions of owner or persons, or any other similar or dissimilar causes beyond control of the company. If you are experiencing pest problems after 7 to 10 days we will render a no charge return call if necessary to give the best possible results for the pests indicated during the guarantee period. This is provided that your account is current and proper preparations have been made. If we do not hear from you, we will assume that the problem has been resolved.

RESPONSIBILITY: We will take all reasonable precautions during the application of pesticides & herbicides for birds, fish, honey bees or other plants; however, we cannot be responsible for their well-being. If you fail to make proper preparations for service, you will not get control of your pest problem and your guarantee may be voided.

This service does not include the control of termites, fungi or wood destroying insects, but does include the insects or pests noted on the Service Agreement and is subject to the terms and conditions above, including your rights under the Federal Truth Lending Law. While the intent of this service is to prevent damage from pests, Armed Force Pest Control, Inc. shall not be liable if such damage should occur during the period such service is rendered.

CHEMICAL	ACTIVE INGREDIENTS	EPA NUMBER	CHEMICAL	ACTIVE INGREDIENTS	EPA NUMBER
4 THE BIRDS- BIRD REPELLANT GEL	POLYBUTENE 93%	8254-5-96	IMIDACLOPRID 2F	IMIDACLOPRID 21.8%	86222-203
885 PLUS XLO	Pyrethrins-0.5% Piperonyl Butoxide - 1.0%	499-290	MAXFORCE ANT GEL BAIT	FIPRONIL 0.001%	64248-21
ADVANCE 375A GRANULAR BAIT	ABAMECTIN B1	499-370	MAXFORCE FC MAGNUM ROACH BAIT	FIPRONIL .001%	432-1460
BEDLAM INSECTICIDE	3-phenoxybenzyl-2, 2-dimethyl-3-cyclopropanecarboxylate 0.40% N-Octyl bicycloheptene dicarboximide, 1.53% BIFENTHRIN 7.9%	1021-1767	MAXFORCE GRANULAR FLY BAIT	0.50% Imidacloprid 0.10% Z-9 Tricosene	432-1375
BIFEN-IT		53883-118	ONSLAUGHT MICROENCAPSULATED INSECTICIDE	benzeneacetate 6.40%	1021-1815
CLEAN AIR PURGE III METERED AEROSOL	Pyrethrins, .975% PBO technical - 1.950% N-Octyl bicycloheptene dicarbimoxide - 3.050%	9444-158	OPTIGARD ANT GEL BAIT	Thiamethoxam 0.010%	100-1280
CONTRAC ALL WEATHER BLOX RODENTICIDE	BROMADIOLONE .005%	12455-79	ORANGE GUARD	D-LIMONENE 5.8%	61887-1-AA
CY KICK CS	CYFLUTHRIN .1%	499-470	PERMETHRIN SFR	PERMETHRIN 36.8%	70506-6-53
CYPER TC	CYPERMETHRIN 25.3%	53883-82	PHANTOM	CHLORFENAPYR 21.45%	241-392
D-FENSE SC	DELTAMETHRIN 4.75%	53883-276	PRECOR IGR CONCENTRATE	METHOPRENE 1.2%	2724-352
DELTA DUST	DELTAMETHRIN .05%	432-772	PT PHANTOM II	IMIDACLOPRID .005%	432-1391
DELTA GARD G	DELTAMETHRIN .10%	432-836	RESOLV SOFT BAIT	CHLORFENAPYR .8%	499-548
DIURON 4L HERBICIDE	DIURON 40%	19713-36	ROUND UP PRO	BROMADIOLONE .005%	7173-297
ECHO ESSENTRIA IC3	Rosemary Oil 10.00% Geraniol 5.00% Peppermint oil 2.00% DIFETHIALONE .0025%	EXEMPT	STERI-FAB INSECTICIDE	GLYPHOSATE 41%	524-475
FIRST STRIKE SOFT BAIT	(S)-Hydroprene (CAS #65733-18-8) 9.0%	7173-258	SUSPEND SC	3-Phenoxybenzyl - 0.22% Isopropyl alcohol - 60.39% Didecyl dimethyl ammonium chloride - 0.114% Dimethyl benzyl ammonium chloride - 0.076%	397-13
GENTROL IGR CONCENTRATE		2724-304-5	TEMPO ULTRA WP	CYFLUTHRIN 10%	432-1304
GLYPHOSATE PRO 4	GLYPHOSATE 41%	72112-4	TERMIDOR SC	FIPRONIL 9.1%	7989-210
			WILCO SQUIRREL BAIT	DIPHACINONE .005%	36029-20

This agreement is for an initial period of 36 month(s).

PREDATOR
Pest & Weed Management
Po Box 1338
Lower Lake Ca 95457
707-995-0230
License #PR11659

5/26-2020

This is an estimate for Weed Control at: South Lake County Fire Protection District
21095 Hwy 175, Middletown CA 95461

Estimated charge \$1,350.00 each on treatment on all areas noted on pictures send it to us.

We normally do first treatment on winter months: November-January.

Second treatment on Spring: April-May

Any other required treatment will be estimated at a discounted price.

This normally occurs the first year.

Any questions please feel free to call us at number above, thanks for considering us.

Martin Ramos.

Re: Weed Control Request attached - South Lake County Fire Middletown Station

RB Pest <rbpcrbpc@gmail.com>

Thu 5/28/2020 7:35 AM

To: Wink, Mike@CALFIRE <Mike.Wink@fire.ca.gov>

Warning: this message is from an external user and should be treated with caution.

that is a one time price for the whole year, we will do follow ups for the year

On Mon, May 18, 2020 at 2:07 PM Wink, Mike@CALFIRE <Mike.Wink@fire.ca.gov> wrote:

That is a one time treatment for that price? Thanks, Mike

Sent from rtpphon

----- Original message -----

From: RB Pest <rbpcrbpc@gmail.com>

Date: 5/18/20 13:39 (GMT-08:00)

To: "Wink, Mike@CALFIRE" <Mike.Wink@fire.ca.gov>

Subject: Re: Weed Control Request attached - South Lake County Fire Middletown Station

Warning: this message is from an external user and should be treated with caution.

I WENT OUT AND LOOKED AT THE AREAS INDICATED ON THE MAPS AND MY ESTIMATE FOR SPRAYING THOSE AREA IS \$1,110.00.

THANK YOU FOR THE OPPORTUNITY TO BID YOU JOB
JOSE HERNANDEZ
OWNER RB PEST CONTROL

On Sun, May 17, 2020 at 6:38 PM Wink, Mike@CALFIRE <Mike.Wink@fire.ca.gov> wrote:

Vendors, please see the attached request for quote/bid for weed spraying services at our Middletown Fire Station. If possible please email a response by COB - Friday May 22nd. Then we can pick a vendor to proceed. Thank you for your time and consideration. All the best, Mike

Mike Wink**Battalion Chief****Middletown Battalion****South Lake County Fire Protection District****21095 Hwy 175 - P.O.Box 1360****Middletown, Ca. 95461**

South Lake County Fire Protection District
21095 Hwy 175
Middletown, Ca. 95461

Mike Wink
mike.wink@fire.ca.gov
mobile 707.889.4225

Weed abatement, fire hazard reduction request via spray treatment request.

Pre-emergent and multiple treatments are a possibility.

Long term from now on this is the plan. Start as soon as possible. I am requesting three bids.

It is approximately 33,293.2 square feet.

It is approximately 0.76 acres.

This does not include the pavement, or blacktop surfaces. That is treating the cracks, so I am not sure how to calculate that.

Attached are the areas to treat with some description.

Section 1 – 6 are all vegetation.

Section 7 – 9 are all pavement cracks and perimeter.

Section 1 - West side of driveway. From fence to pavement and 10 feet off the back.

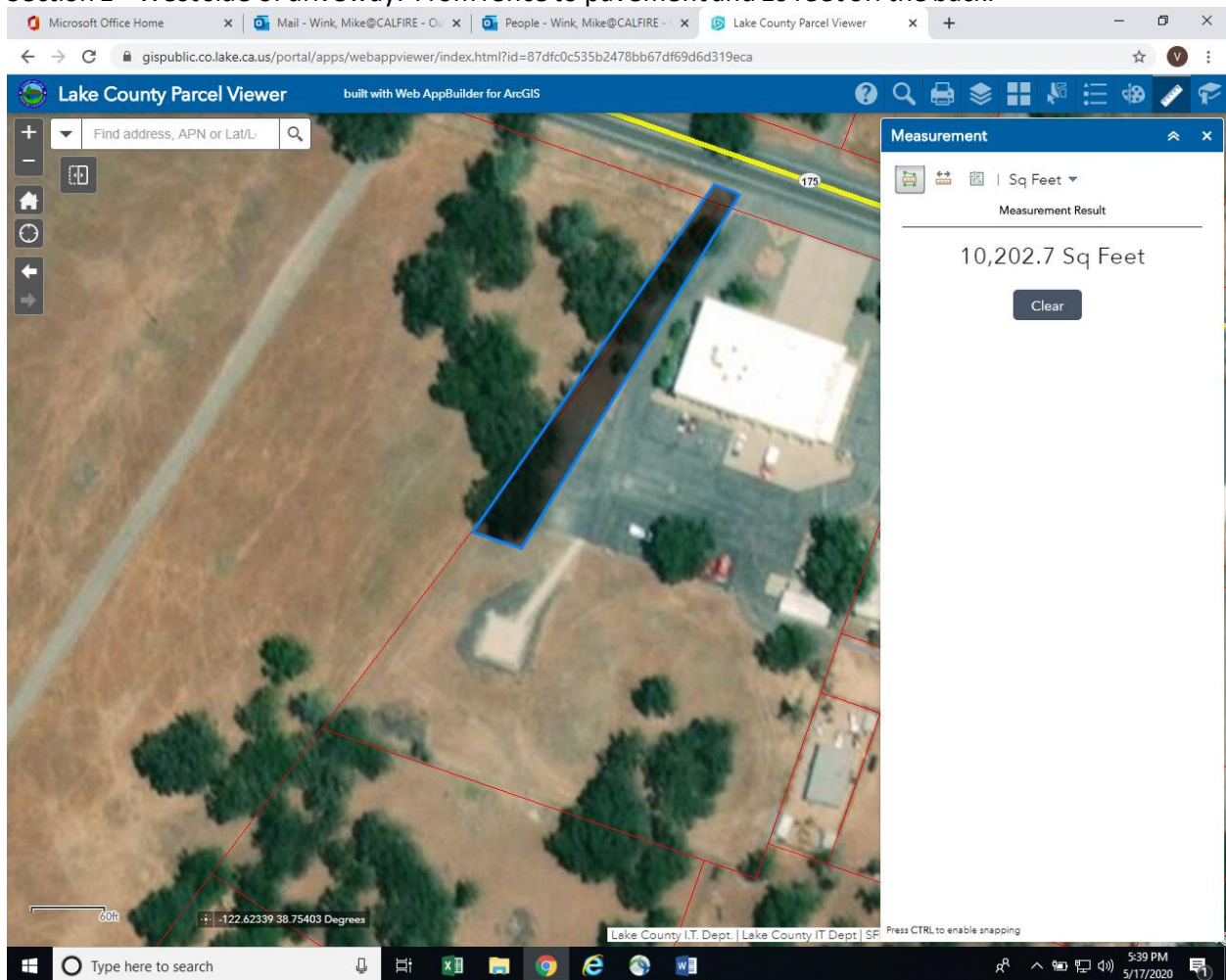

Section 2 – Ten feet off the perimeter of the Helicopter landing zone structure.

The screenshot displays the 'Lake County Parcel Viewer' web application. The browser's address bar shows the URL: gispublic.co.lake.ca.us/portal/apps/webappviewer/index.html?id=87dfc0c535b2478bb67df69d6d319eca. The application interface includes a search bar with the text 'Find address, APN or Lat/L', a map of an aerial view with a blue polygon highlighting a specific area, and a 'Measurement' panel on the right. The measurement panel shows a result of '5,605.9 Sq Feet' and a 'Clear' button. The bottom of the screen shows a Windows taskbar with the search bar, taskbar icons for various applications, and the system tray showing the time as 5:41 PM on 5/17/2020.

Microsoft Office Home | Mail - Wink, Mike@CALFIRE - O... | People - Wink, Mike@CALFIRE - X | Lake County Parcel Viewer

gispublic.co.lake.ca.us/portal/apps/webappviewer/index.html?id=87dfc0c535b2478bb67df69d6d319eca

Lake County Parcel Viewer built with Web AppBuilder for ArcGIS

Find address, APN or Lat/L

Measurement

Sq Feet

Measurement Result

5,605.9 Sq Feet

Clear

60R -122.62136 38.75416 Degrees

Lake County I.T. Dept. | Lake County IT Dept | SF Press CTRL to enable snapping

Type here to search

5:41 PM 5/17/2020

Section 3 – Utility Safety Prop Area and 10 feet off the read of the parking lot including the tree area.

The screenshot displays the Lake County Parcel Viewer web application. The browser address bar shows the URL: gispublic.co.lake.ca.us/portal/apps/webappviewer/index.html?id=87dfc0c535b2478bb67df69d6d319eca. The application interface includes a search bar with the text "Find address, APN or Lat/L", a map of an aerial view with red parcel boundaries, and a "Measurement" panel on the right. The measurement panel shows a result of "7,500.6 Sq Feet" and a "Clear" button. The map shows a blue-outlined area with a brown fill, representing the utility safety prop area. The bottom of the screen shows a Windows taskbar with the search bar, taskbar icons, and system tray showing the time as 5:43 PM on 5/17/2020.

Section 4 – Generator area, break area and shed area.

The screenshot displays the Lake County Parcel Viewer web application interface. The browser's address bar shows the URL: gispublic.co.lake.ca.us/portal/apps/webappviewer/index.html?id=87dfc0c535b2478bb67df69d6d319eca. The application header includes the title "Lake County Parcel Viewer" and the text "built with Web AppBuilder for ArcGIS". A search bar at the top left contains the text "Find address, APN or Lat/L". The main map area shows an aerial view of a residential or commercial area with red parcel boundaries. A specific parcel is highlighted with a blue outline. A yellow line is drawn along a road labeled "PARRY AVE" with a "178" shield. On the right side, a "Measurement" panel is open, displaying "Sq Feet" as the unit and a "Measurement Result" of "4,050.1 Sq Feet". A "Clear" button is located below the result. The bottom of the screen shows a Windows taskbar with the search bar, taskbar icons for Microsoft Office, Chrome, and other applications, and a system tray showing the time as 5:44 PM on 5/17/2020. The application footer includes the text "Lake County I.T. Dept. | Lake County IT Dept | SF" and "Press CTRL to enable snapping".

Section 5 – Training area.

The screenshot displays the Lake County Parcel Viewer web application interface. The browser's address bar shows the URL: gispublic.co.lake.ca.us/portal/apps/webappviewer/index.html?id=87dfc0c535b2478bb67df69d6d319eca. The application header includes the title "Lake County Parcel Viewer" and the text "built with Web AppBuilder for ArcGIS". A search bar at the top left contains the text "Find address, APN or Lat/L". The main map area shows an aerial view of a residential area with red parcel boundaries. A specific parcel is highlighted with a blue border. A yellow line is drawn across the top of the map, and a road labeled "175" is visible. On the right side, a "Measurement" panel is open, displaying the unit "Sq Feet" and the "Measurement Result" of "20,079.9 Sq Feet". Below the result is a "Clear" button. The bottom of the screen shows the Windows taskbar with the search bar, taskbar icons for various applications, and the system tray showing the time as 5:46 PM on 5/17/2020.

Section 6 – Thrift Shop area.

The screenshot displays the Lake County Parcel Viewer web application. The browser's address bar shows the URL: gispublic.co.lake.ca.us/portal/apps/webappviewer/index.html?id=87dfc0c535b2478bb67df69d6d319eca. The application interface includes a search bar with the text "Find address, APN or Lat/L", a map of a thrift shop area with red parcel boundaries and a blue highlighted building, and a "Measurement" panel on the right. The measurement panel shows a result of "3,924 Sq Feet" and a "Clear" button. The bottom of the screen shows the Windows taskbar with the search bar, taskbar icons, and system tray showing the time as 5:47 PM on 5/17/2020.

Microsoft Office Home x Mail - Wink, Mike@CALFIRE - O... x People - Wink, Mike@CALFIRE - x Lake County Parcel Viewer x +

gispublic.co.lake.ca.us/portal/apps/webappviewer/index.html?id=87dfc0c535b2478bb67df69d6d319eca

Lake County Parcel Viewer built with Web AppBuilder for ArcGIS

Find address, APN or Lat/L

Measurement

Sq Feet

Measurement Result

3,924 Sq Feet

Clear

60ft -122.62108 38.75322 Degrees Lake County I.T. Dept. | Lake County IT Dept | SF Press CTRL to enable snapping

Type here to search

5:47 PM 5/17/2020

Section 7 – Park and Ride area. Perimeter to fences and all pavement cracks.

The screenshot displays the Lake County Parcel Viewer web application. The browser's address bar shows the URL: gispublic.co.lake.ca.us/portal/apps/webappviewer/index.html?id=87dfc0c535b2478bb67df69d6d319eca. The application interface includes a search bar with the text "Find address, APN or Lat/L", a map of an aerial view with red parcel boundaries, and a blue polygon highlighting a specific area. A "Measurement" panel on the right displays the result: "16,285.7 Sq Feet". The map also shows "PARK AVE" and "GRAHAM" streets, and a "176" highway marker. The bottom of the screen shows the Windows taskbar with the search bar and system tray.

Microsoft Office Home | Mail - Wink, Mike@CALFIRE - O... | People - Wink, Mike@CALFIRE - | Lake County Parcel Viewer

gispublic.co.lake.ca.us/portal/apps/webappviewer/index.html?id=87dfc0c535b2478bb67df69d6d319eca

Lake County Parcel Viewer built with Web AppBuilder for ArcGIS

Find address, APN or Lat/L

PARK AVE

176

GRAHAM

Measurement

Sq Feet

Measurement Result

16,285.7 Sq Feet

Clear

66R

-122.62194 38.75352 Degrees

Lake County I.T. Dept. | Lake County IT Dept | SF Press CTRL to enable snapping

Type here to search

5:48 PM 5/17/2020

Section 8 – Training grounds area. Spray perimeter and all pavement cracks.

The screenshot displays the Lake County Parcel Viewer web application interface. The browser's address bar shows the URL: gispublic.co.lake.ca.us/portal/apps/webappviewer/index.html?id=87dfc0c535b2478bb67df69d6d319eca. The application title is "Lake County Parcel Viewer" and it is noted as being "built with Web AppBuilder for ArcGIS".

The main map area shows an aerial view of a property with a large building footprint outlined in blue. A yellow line highlights a road labeled "176" and "PARK AVE". Other roads visible include "GRAHAM". The map includes a search bar at the top left with the placeholder text "Find address, APN or Lat/Li".

On the right side, a "Measurement" panel is open, displaying the following information:

- Measurement Result: 45,963.9 Sq Feet
- A "Clear" button is located below the measurement result.

The bottom of the screenshot shows the Windows taskbar with the search bar containing "Type here to search", several application icons (including Microsoft Office and Chrome), and the system tray showing the time as 6:05 PM on 5/17/2020. A status bar at the bottom of the application window reads "Lake County I.T. Dept. | Lake County IT Dept | SF" and "Press CTRL to enable snapping".

Section 9 – Fire station pavement perimeter and all cracks.

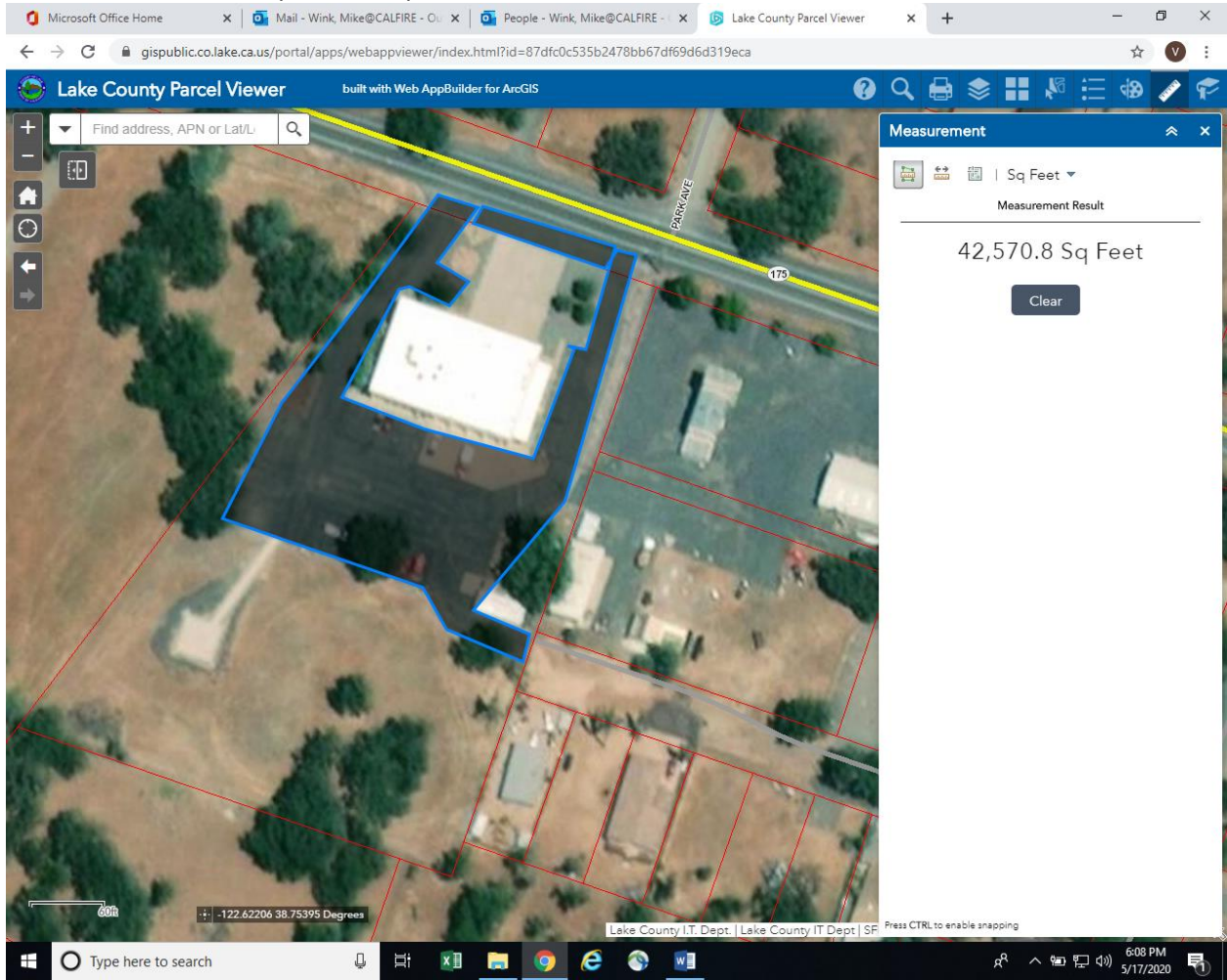



South Lake County Fire Protection District
— in cooperation with —
California Department of Forestry and Fire Protection

P.O. Box 1360 Middletown, CA 95461 (707) 987-3089

To: Board of Directors

February 12, 2020

From: Battalion Chief Mike Wink
Engineer Paramedic Anthony Dozier

Re: Staff Summary for SCBA Bottles et'al

Summary

The intent of this letter is to present facts pertaining to the status of South Lake County Fire Protection District's Self Contained Breathing Apparatus (SCBA). Each Piece of Apparatus, except for the Utilities (Pickup trucks), are equipped with SCBA's and spare cylinders. This is a fire service standard practice, There are time when we have used all available SCBAs at the scene of a emergency

The SCBA consists of multiple major components. The facepiece (mask), harness and backpack assembly, hoses and regulators (high and low pressure), integrated control module with PASS Device, and high pressure cylinder.

The current Facepiece we are equipped with (MSA Ultra Elite) was designed to withstand and provide protection to the user against thermal temperatures and degradation consistent with UL Research during the time it was first manufactured, in the early 2000's. Since then, the leaders in Fire Service Standards and Technology (NFPA, NIST, NIOSH, ANSI, UL) have conducted countless hours of research pertaining to modern fire behavior and modern fuels found within our homes and the temperatures created. They found that Facepiece Degradation and thermal failure resulted in multiple Firefighter Fatalities in the Fire Service. The Research prompted NFPA to draft a new set of guidelines. All Manufacturers now adhere to these guidelines. Our Facepiece does not meet any current standard for protection.

SCBA's use Pressurized Cylinders to provide Breathing Air to First Responders while working within atmospheres that present immediate danger to life and health. These Cylinders have a life span that is set by the manufacturer of 15 years. This life span cannot be extended as it reflects the structural integrity of the 4500psi high pressure cylinder. We have approximately 75 SCBA Cylinders that will need to be replaced before June 2021.

While grant options are being sought, and Measure L Funds will soon be prioritized there are some interim options to consider for replacement of our aging SCBA fleet.

Options:

1. Purchase 75 new SCBA Bottles that will have a 15-year life span. This will exceed our SCBAs useful in service expected period. New bottles are \$800.00 each plus tax, shipping and any necessary retrofitting. That would be \$60,000.00 plus tax and shipping.

2. Purchase 75 refurbished / used and inspected SCBA bottles that have a minimum life span of 5 years. This will give us five years to be awarded a grant, or a loan, or the use of Measure L Funds. The bottles are \$300.00 each plus tax, shipping and any necessary retrofitting. That would be \$22,500.00 plus tax and shipping.
3. Purchase 40 facepieces that meet the new standards. The cost \$700.00 each. Then we would need spares and spare parts for this new face piece. They are \$700 each which would be \$28,000.00. Then we could need and additional \$20,000.00 for new parts.
4. Purchase all new SCBAs and spare bottles.
 - SCBA complete w/ Facepiece and Cylinder- $\$5,000 \times 42 =$ Approximately \$210,000.
 - SCBA Cylinders (additional to support operations) - $\$800 \times 48 =$ \$38,400
 - The above rates are contracted through Scott for CAL FIRE and Special Districts Associated with CAL FIRE. Normal costs exceed \$7,000 for the SCBA and \$1,000 for the Cylinders.
 - We can continue to write grants after purchase to cover the remaining cost.
 - 15 year service plan included in the cost.
 - 42 complete Packs & Masks w/bottles
 - 48 Spare bottles
 - 10 extra masks
 - 7 RIC packs
 - 40 brackets
 - This would be \$248,400.00 plus the extra RIC packs, masks and mounting brackets.

Recommendation:

Option #2 gives us five years to plan for a full replacement of all SCBA components. This will allow grant to be awarded or to plan to use Measure L Funds.

Re: South Lake County Fire Station Survey

Wink, Mike@CALFIRE <Mike.Wink@fire.ca.gov>

Sun 6/14/2020 11:37 PM

To: Jon Webb <jwebb@albionsurveys.com>

Cc: Duncan, Paul@CALFIRE <Paul.Duncan@fire.ca.gov>; Joe Sullivan <jsullivan@albionsurveys.com>

Good evening Mr Webb. Thank you for the discounted pricing opportunity of the \$3500.0 plus the County Fee's. Fire District Purchasing Policy requires I check with two other vendors for a similar estimate. Once I do that I will let you know. Sincerely, Mike

From: Jon Webb <jwebb@albionsurveys.com>

Sent: Thursday, June 11, 2020 2:19 PM

To: Wink, Mike@CALFIRE <Mike.Wink@fire.ca.gov>

Cc: Duncan, Paul@CALFIRE <Paul.Duncan@fire.ca.gov>; Joe Sullivan <jsullivan@albionsurveys.com>

Subject: RE: South Lake County Fire Station Survey

Warning: this message is from an external user and should be treated with caution.

Mike

Our fees would be \$5500 plus the County Map fee of \$403

We are always big supporters of South Lake Fire so we would reduce our fees \$3500 plus the County fee, or we can charge you the full amount and donate back \$2,000,

obviously the donate back is better for me but not imperative

Let me know if any of these scenarios work for you and I can write a formal proposal

Thank You

Jon M Webb, PLS 6709

Albion Surveys, Inc.

1113 Hunt Avenue

Saint Helena, CA 94574

707-963-1217, ext 117

707-963-1829(facsimile)

jwebb@albionsurveys.com

Electronic Data User Agreement

The Electronic Data User Agreement is a legal agreement between the user of the attached files and Albion Surveys, Inc. (ASI). You do not need to sign or acknowledge this Agreement in order for it to take effect.

By opening, installing, copying, or otherwise using the attached files you are agreeing to be bound by the terms described below. If you do not agree to the terms of this agreement, ASI is unwilling to allow the use of these files to you. In such event, you must not open these files and must return them promptly to ASI.

The documentation and all ideas, aesthetics and designs incorporated herein are instruments of service and as such are the registered property of ASI, and cannot be lawfully used without permission. The recipient is granted a license for use, but only in the execution of "the project". Use of these materials for modification, extension, alteration or expansion of this project or on any other project, unless under the direction of ASI is prohibited and neither ASI nor its consultants assume any liability for such usage. ASI makes no representation concerning the accuracy of this documentation and is not responsible for any errors and/or omissions that may be incorporated herein.

Because data stored in electronic media can be altered, either intentionally or unintentionally, by transcription, computer error, environmental factors, or by operator error, it is agreed that by opening, installing, copying or otherwise using the attached files, you are also agreeing to save, indemnify, defend and hold harmless ASI and its consultants from and against any and all claims, liabilities, losses, damages and costs, including but not necessarily limited to costs of defense, arising out of use, changes or modifications to the electronic media outside the license granted by this agreement.

Please be advised that, in the case of existing construction, the documents requested are reproductions of documentation on file and do not necessarily represent as-built or existing conditions. ASI does not warrant, in any way, the accuracy of this information and shall not be responsible for any discrepancy between this documentation and the existing conditions. In the case of projects that are currently being designed and/or under construction, the electronic documentation are reproductions of the documentation on file and may be subject to change due to Owner, field and/or coordination revisions. ASI shall not be responsible for reissuing files that may be revised after issuance of these requested files and shall not be responsible for advising other parties as to the status of document revisions.

Warning: This file is furnished without guarantee of compatibility with recipient's hardware or software and may contain undetected viruses or other harmful material. It is recommended that this file be checked prior to use. ASI assumes no responsibility for damage to user's property as a result of using this file and/or its contents.

From: Wink, Mike@CALFIRE <Mike.Wink@fire.ca.gov>

Sent: Thursday, June 11, 2020 11:23 AM

To: Jon Webb <jwebb@albionsurveys.com>

Cc: Duncan, Paul@CALFIRE <Paul.Duncan@fire.ca.gov>; Joe Sullivan <jsullivan@albionsurveys.com>

Subject: Re: South Lake County Fire Station Survey

Good morning Mr Webb and Team. Thank you, and we will talk to you soon. Mike

From: Jon Webb <jwebb@albionsurveys.com>

Sent: Thursday, June 11, 2020 11:18 AM

To: Wink, Mike@CALFIRE <Mike.Wink@fire.ca.gov>

Cc: Duncan, Paul@CALFIRE <Paul.Duncan@fire.ca.gov>; Joe Sullivan <jsullivan@albionsurveys.com>

Subject: RE: South Lake County Fire Station Survey

Warning: this message is from an external user and should be treated with caution.

Hi Mike

I wanted to let you know we are working on your quote, just waiting on some deeds from the County Recorders office

Thank You

Jon M Webb, PLS 6709

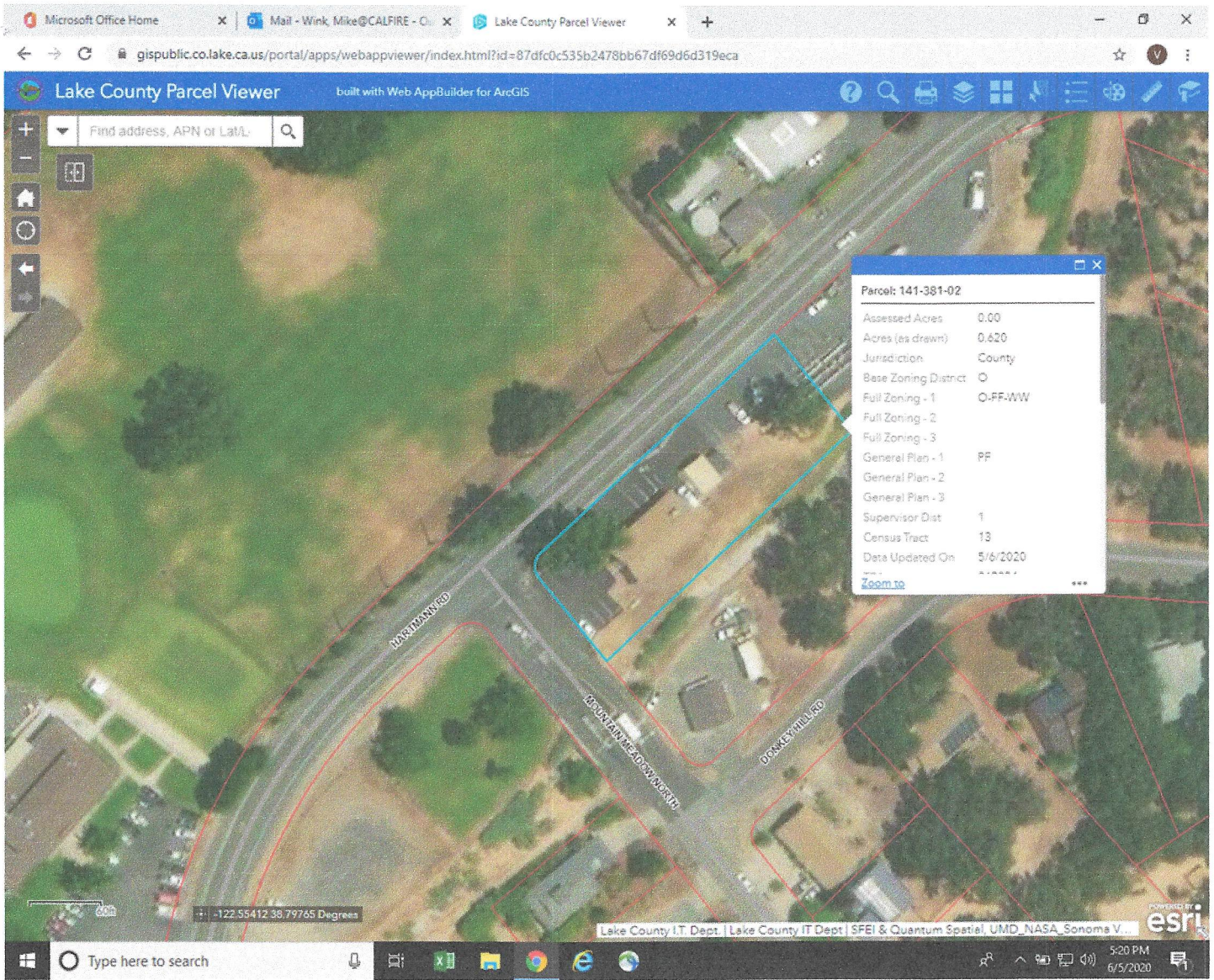

Mike Wink

Battalion Chief

Middletown Battalion

South Lake County Fire Protection District

Sonoma - Lake - Napa Unit

21095 Hwy 175 - P.O.Box 1360

Middletown, Ca. 95461

Office: 707.987-3089 ext 3

Cell: 707.889.4225

Fax: 707.987.9478

Emial Mike.Wink@fire.ca.gov

Survey

Norman Stewart <NormanS@ruzicka-engineering.com>

Mon 7/6/2020 9:01 AM

To: Wink, Mike@CALFIRE <Mike.Wink@fire.ca.gov>

Warning: this message is from an external user and should be treated with caution.

Hi Mike,

I regret to inform that we are not taking on new work for the next couple of months. Let me know if it can wait until then and I will put you on my waiting list and contact you then.

Good luck with your project.

Norman Stewart
Senior Surveying Technician
Ruzicka Associates
2495 Parallel Drive
Lakeport, CA 95453
707-263-6155
Cell 707-245-1489
normans@ruzicka-engineering.com



This email has been checked for viruses by AVG antivirus software.
www.avg.com

CONSER

LAND SURVEYING

Michael S. Conser LS 8383
July 7, 2020

Mike Wink
c/o
South Lake County Fire Protection District
P.O. Box 1360
Middletown, CA 95461

(707) 987-3089 Ext. 3

Ref: Surveying Services for A.P.N. 141-381-02, 19287 Hartmann Road, Hidden Valley, CA, Lake County Records.

Mike,

In accordance with your request, Conser Land Surveying is pleased to submit this proposal to provide surveying services for the referenced tracts per our discussion, which is referred to herein as the project. After execution of this document and your authorization to proceed, Conser Land Surveying will provide the following scope of services based upon our understanding of the project.

SURVEYING SERVICES

1. Office administration and calculations.
2. Field survey to locate and verify the position and character of any existing survey monuments, per Lake County Records.
3. Evaluate the found evidence to resolve the boundary of said tract.
4. Provide additional field surveying to reestablish the boundary of said tract, if necessary.
5. Set the corner(s) of said tract, if required.
6. Prepare and file a Record of Survey with the County of Lake, if required.
7. Topographic Survey of the site for design purposes with assumed elevations.
8. Prepare Topographic Plat to be delivered in CAD format and standard hard copy.

Please initial and date here: _____

CONSER

LAND SURVEYING

PROFESSIONAL FEES

Items 1-8

Time and Material Estimate: \$6,500.00

Retainer: A retainer of \$3,250.00 and a signed acknowledgement will be required to begin the project. Please initial and date pages one and two, sign and date page three and return to us with the required retainer.

Note: The fees as shown are an estimate for services: Fees may vary due to unforeseen issues out of the control of Conser Land Surveying, if the fees are going to exceed the high end of the estimate by more than 10%, the client will be notified immediately to discuss.

If you wish to use a credit card, we accept Visa, Mastercard and Discover. A 4% convenience fee will be added to each credit card transaction.

Please initial & date here: _____

TERMS AND CONDITIONS

Conser Land Surveying liability is limited to the negligence, willful misconduct or omissions of its own employees, agents, sub consultants and subcontractors. This proposal is subject to the laws of the State of California and once executed will remain in effect until December 31, 2020. At which time Conser Land Surveying reserves the right to increase fees remaining for unrendered services described in this proposal 2.5% due to increase in labor and material cost. Any increase more than 2.5% will be negotiated with the client. In the event of a controversy, claim or dispute between Conser Land Surveying and the client arising out of or relating to the project, the prevailing party shall be entitled to recover attorney fees, expenses cost whether or not litigation is instituted.

*** The project will be progress billed bi-weekly after 50% of the retainer has been utilized, with that amount being applied to first invoice. The remaining 50% of the retainer will be held and utilized to cover the final invoice and recordation fees, if applicable. Projects requiring peer review from the County Surveyor will not be submitted until all invoices are paid. No final product(s) will be delivered until all services have been billed and invoices paid. Payment for the services described above will be due upon receipt of a statement for our work performed during the preceding billing period. Invoices not paid within 14 days of the date of invoice will result in a project hold and are subject to an interest charge of 1% per month and compounding monthly until paid in full. Any remaining monies will be returned to the client immediately following project completion. In the event that the contract is mutually terminated, any prior work completed shall be billed as services rendered and any monies received over and above the final bill shall be returned to the client. ***

CONSER

LAND SURVEYING

Should you require additional services, other than those detailed in this proposal, such additional services shall be based upon Conser Land Surveying current Hourly Rate Schedule. Additional services will be performed after written authorization from the client or the client's on site representative. Pursuant to California law, the client is noticed that at a future date Conser Land Surveying may claim a lien as provided by law against the property if not paid in full.

Either party may terminate this Contract on ten (10) calendar days written notice, or if prior to such action, the other party materially breaches any of its representations, warranties or obligations under this agreement. In the event that the contract is terminated, any prior work completed shall be billed as services rendered and any monies received over and above the final bill shall be returned to the client.

The files, field notes, control network data and/or all other information gathered or created in relation to this project are instruments of service and not a product, unless it is of public record. All instruments of service as stated are the sole property of Conser Land Surveying, thus distribution or use thereof is at the sole discretion of Conser, and may not be reproduced or distributed without written consent from Conser Land Surveying.

We appreciate the opportunity to provide our services and look forward to working with you. If this proposal is satisfactory to you, please indicate your agreement by signing and returning one original copy and the required retainer as our notice to proceed. Please call us if of you have any questions regarding this proposal, or if we can be of further service.

Sincerely,

Michael S. Conser

Principal

CONSER LAND SURVEYING

ACCEPTED

BY: _____

DATE: _____



South Lake County Fire Protection District
— in cooperation with —
**California Department of Forestry and Fire
Protection**

P.O. Box 1360 Middletown, CA 95461 (707) 987-3089

STAFF REPORT

To: South Lake County Fire Protection District Board of Directors

From: Jon Hoag, Fire Captain Station 62

Re:

SUMMARY

Fire Captain Jon Hoag was asked to gather bids to lease 2 MSA Altair 4X gas monitors and 2 MAS GX2 calibration stations, that meet the requirements outlined by the LNU Ops Working Group. These monitors are currently being used throughout Napa County Fire District/CAL Fire. The Units will be able to monitor CA, O2, LEL and H2S.

EXECUTIVE SUMMARY

The intent of providing this information is so the BOD can decide if they would like to consider these proposals for the needed replacement of our current OOS Drager X am-2000 4 gas monitors.

BACKGROUND

South Lake County Fire Protection District has been utilizing 3 Drager X-am 2000 4 gas monitors for over 8 years. The units have had several costly repairs in the recent years and currently all 3 of the 4 gas monitors have a least 1 faulty sensor each. In addition to the cost of the repairs, each unit must be sent back to the manufacture and no loaner is provided meaning that we are down a unit while it is serviced and repaired. Finally, our calibration gas has expired and new gas is very costly.

ANALYSIS

Leasing 2 new MSA Altair 4X gas monitors with 2 GX2 calibration stations will give us the ability to always have 2 working 4 gas monitors. The 36-month Freedom Lease Plan includes maintenance plan and 90 day on site calibrations, user training, loaner program, Calibration gas, and field verification equipment.

FISCAL IMPACTS

Lease: Air Instrumentation of California

2 MSA Altair 4X gas monitors \$2,610.00

2 GX2 calibration stations \$2,600.00

Total (tax included): \$5,399.23

Purchase: LN Curtis

2 MSA Altair 4X gas monitors \$4,200.00

2 GX2 Electronic cylinder holder \$2,364.00

2 Galaxy GX2 automated test system \$3,840

2 34 L 4 gas calibration cylinder \$580.00

Total (tax included): \$11,780.34

Bauer

2 MSA Altair 4X gas monitors \$4,212.20

2 GX2 Charger/ calibration stations \$4,159.86

2 34 L 4 gas calibration cylinder \$459.02

2 Cylinder Holder \$434.72

Total (tax included): \$9,937.57

Lease Vs Purchase

The 36-month Freedom Lease Plan includes maintenance plan and 90 day on site calibrations, user training, loaner program, Calibration gas, and field verification equipment. With the lease any out of service 4 gas monitors will be replaced with a loaner unit while repairs or maintenance is preformed. With the purchase of new 4 gas monitors, all maintenance and repairs outside of warranty will be an additional cost. During maintenance and repair we will be without one or possible both 4 gas monitors for an extended period.

RECOMMENDATION

Lease 2 new MSA Altair 4X gas monitors with 2 GX2 calibration stations.



South Lake County Fire Protection District
— in cooperation with —
California Department of Forestry and Fire Protection

P.O. Box 1360 Middletown, CA 95461 - (707) 987-3089

DATE: August 16, 2019
TO: Board of Directors
FROM: Gloria Fong
Staff Services Analyst
SUBJECT: Resolution 2020-21 04, A Resolution Directing Fire Chief, or Designee, to Certify and Request County of Lake to Collect Special Tax on the 2020-2021 County Tax Rolls

Subject resolution is attached for Board's approval. The data provided is that of which was approved from the July meeting with 2.3% CPI escalation. This will be corrected evening of the meeting. Additional time is necessary to verify this information with the data recently received.

Attachments

BOARD OF DIRECTORS, SOUTH LAKE COUNTY FIRE PROTECTION DISTRICT

COUNTY OF LAKE, STATE OF CALIFORNIA

RESOLUTION NO. 2020-21 04

**A RESOLUTION DIRECTING FIRE CHIEF, OR DESIGNEE,
TO CERTIFY AND REQUEST COUNTY OF LAKE
TO COLLECT SPECIAL TAX ON THE 2020-2021 COUNTY TAX ROLLS**

1 **RESOLVED**, by the Board of Directors of the South Lake County Fire Protection District that
2 it Finds, Determines, Orders and hereby declares THAT:

- 3
- 4 1) On November 6, 2018, the voters of the South Lake County Fire Protection District
5 approved a special tax levy Ordinance No. 2018-19 01, authorizing the District to
6 impose and levy a special tax on each parcel of real property located within its
7 boundaries. A list of which is attached hereto as Exhibit "A" and, by this reference,
8 incorporated herein, for a number of 8970 assessments, for a total of \$ 1,899,517.
- 9 2) This Board, for and on behalf of South Lake County Fire Protection District authorizes
10 and directs Fire Chief, or designee, to certify and request County of Lake to collect
11 special tax on the 2020-2021 County Tax roll, and to make adjustments of special tax as
12 the Fire Chief, or designee, deems appropriate.
- 13

14 **THIS RESOLUTION** was introduced and adopted by the Board of Directors of the South
15 Lake County Fire Protection District on the 18th day of August, 2020, by the following vote:

AYES:

NOES:

ABSENT OR NOT VOTING:

[SEAL]

SOUTH LAKE COUNTY
FIRE PROTECTION DISTRICT

MADELYN MARTINELLI
President, Board of Directors

ATTEST: _____
Gloria Fong
Clerk to the Board of Directors

SOUTH LAKE COUNTY FIRE PROTECTION DISTRICT

REPORT OF REAL PROPERTY SUBJECT TO SPECIAL TAX TO BE COLLECTED ON 2020-2021 COUNTY TAX ROLLS

	#	Units	#	Amt	Amt
Vacant 0 to 1 ac	2398	38368			383,680
Vacant 1.01 to 5 ac	334	5678			56,780
Vacant 5.01 to 10 ac	170	3060			30,600
Vacant 10.01 to 50 ac	629	12580			125,800
Subtotal	3531	59686	0	-	596,860
Orchard/Vineyard 10.01 to 50 ac	1	19			190
Orchard/Vineyard +50.01 ac	12	240			2,400
Subtotal	13	259	0	-	2,590
Res / Ag Misc Bldg	1	25			250
Res / Ag Single Family Dwelling	5056	101120	21	2,800	1,014,000
Res / Ag Single w-multiple	27	1080			10,800
Res / Ag Triplex	6	270			2,700
Subtotal	5090	102495	21	2,800	1,027,750
Hotels / Motels	14	420	3	2,350	6,550
Mobile Home Park / Campground	5	375	1	1,050	4,800
Comm 0-999 Sq Ft	24	3960			39,600
Comm 1,000-4,000 Sq Ft	90	16650			166,500
Comm 5,000-9,999 Sq Ft	15	3000			30,000
Comm 10,000+ Sq Ft	8	2000			20,000
Subtotal	156	26405	4	3,400	267,450
Grand Total	8790	188845	25	6,200	1,894,650
				CORRECTIONS	(37,840)
				CORRECTED GRAND TOTAL	1,856,810
				December to December 2.3% CPI	1,899,517



South Lake County Fire Protection District
 ——— in cooperation with ———
California Department of Forestry and Fire Protection

P.O. Box 1360 Middletown, CA 95461 - (707) 987-3089

DATE: August 14, 2020
TO: Board of Directors
FROM: Gloria Fong
 Staff Services Analyst
SUBJECT: Resolution No. 2020-21-05, A Resolution Authorizing the Fire Chief to Execute Agreements for Participation in the Intergovernmental Transfer of Public Funds Program for the Service Periods, July 1, 2019 through June 30, 2020, and July 1, 2020 through December 31, 2020

Attached for the Board’s consideration is subject resolution for the Intergovernmental Transfer (IGT) Program. Due to the timelines involved in the process to have agreements in place, it is recommended the Fire Chief be given the authority to execute the agreements, as in past years.

Participation in the IGT Program is voluntary. To be considered a participating entity, the agency must first submit letter of interest (attached). Following receipt of participating agencies, Department of Health Care Services (DHCS), prepares projects non-federal contribution amounts for each agency. The IGT Return supplements the short fall in payments for Medi-Cal patients.

The IGT return is intended to supplement the short fall in payments the District is allowed to collect from Medi-Cal patient transports. Participating agencies cannot use the IGT return for future year contributions and therefore are placed into reserves and designated for use in medical equipment replacement expenses. As of 06/30/2020, this balance is \$328,783. IGT funds have been used to purchase new monitors and district’s share of M6211.

Percentage of return varies as this depends upon a members Medi-cal patient transport #s and # of participating agencies. For example, lesser patients mean less District share in contribution amounts, more participating agencies means less return in IGT funds. Below are prior year District share contributions and their returns. On tonight’s adopted budget I don’t recommend any change to original estimates. Provided the IGT return doesn’t fall too short or higher than the District share budgeted amounts, budgetary adjustments won’t be necessary.

	7/1-12/31/20	FY 2019-20	FY 2018-19	FY 2017-18	FY 2016-17	FY 2015-16	FY 2014-15
District Share	76,790	140,457	258,362	33,038	80,347	80,347	358,636
IGT Return			409,116	20,301	79,415	84,409	353,740
% of Return			158.4%		98.8%	105.1%	98.6%
Est. Return - low %	46,175	86,309		61.4%			
Est. Return – avg %	80,219	146,730	104.5%	5 yr average			

Note the rate of return is high in FY 2018-19 as Partnership Health waived the administrative fee due to the COVID situation.

Attachments

BOARD OF DIRECTORS, SOUTH LAKE COUNTY FIRE PROTECTION DISTRICT
COUNTY OF LAKE, STATE OF CALIFORNIA

RESOLUTION NO. 2020-21 05

A RESOLUTION AUTHORIZING THE FIRE CHIEF TO EXECUTE AGREEMENTS FOR PARTICIPATION IN THE INTERGOVERNMENTAL TRANSFER OF PUBLIC FUNDS PROGRAM FOR THE SERVICE PERIODS, JULY 1, 2019 THROUGH JUNE 30, 2020, AND JULY 1, 2020 THROUGH DECEMBER 31, 2020

WHEREAS, the South Lake County Fire Protection District in working with Partnership HealthPlan of California (PHC) and California Department of Health Care (DHCS) Services submitted letter of interest and would like to participate with its nonfederal share towards the Rate Range Program for service periods of July 1, 2019 through June 30, 2020 and July 1, 2020 through December 31, 2020;

WHEREAS, the Board of Directors of South Lake County Fire Protection District is willing to contribute up to the maximum amount allowable as calculated by DHCS as the nonfederal share of this Intergovernmental Transfer (IGT) and negotiated with PHC;

WHEREAS, the Board of Directors of South Lake County Fire Protection District recognizes that PHC may retain up to ten percent (10%) for cost to administer this program and that DHCS may have sole discretion to determine the amount of the funds transferred be subject to a twenty percent fee (20%).

NOW, THEREFORE, BE IT RESOLVED, that the Board of Directors of South Lake County Fire Protection District hereby authorizes the Fire Chief to execute Intergovernmental Agreement Regarding Transfer of Public Funds, Intergovernmental Transfer Assessment Fee Agreement, and Amendment to the Health Plan-Provider Agreement with Partnership HealthPlan of California.

THIS RESOLUTION was introduced and adopted by the Board of Directors of the South Lake County Fire Protection District at a special meeting held on the 18th day of August, 2020 by the following vote:

AYES:

NOES:

ABSENT OR NOT VOTING:

[SEAL]

SOUTH LAKE COUNTY
FIRE PROTECTION DISTRICT

ATTEST: _____
Gloria Fong
Clerk to the Board of Directors

MADELYN MARTINELLI
President, *Board* of Directors

**INTERGOVERNMENTAL AGREEMENT REGARDING
TRANSFER OF PUBLIC FUNDS**

This Agreement is entered into between the CALIFORNIA DEPARTMENT OF HEALTH CARE SERVICES (“DHCS”) and the SOUTH LAKE COUNTY FIRE PROTECTION DISTRICT (GOVERNMENTAL FUNDING ENTITY) with respect to the matters set forth below.

The parties agree as follows:

AGREEMENT

1. Transfer of Public Funds

1.1 The GOVERNMENTAL FUNDING ENTITY agrees to make a transfer of funds to DHCS pursuant to sections 14164 and 14301.4 of the Welfare and Institutions Code. The amount transferred shall be based on the sum of the applicable rate category per member per month (PMPM) contribution increments multiplied by member months, as reflected in Exhibit 1. The GOVERNMENTAL FUNDING ENTITY agrees to initially transfer amounts that are calculated using the Estimated Member Months in Exhibit 1, which will be reconciled to actual enrollment for the service periods of July 1, 2019 through June 30, 2020, and July 1, 2020 through December 31, 2020, and reconciled to actual PMPMs for the service period of July 1, 2020 through December 31, 2020 in accordance with Sub-Section 1.3 of this Agreement. The funds transferred shall be used as described in Sub-Section 2.2 of this Agreement. The funds shall be transferred in accordance with the terms and conditions, including schedule and amount, established by DHCS.

1.2 The GOVERNMENTAL FUNDING ENTITY shall certify that the funds transferred qualify for Federal Financial Participation pursuant to 42 C.F.R. part 433, subpart B, and are not derived from impermissible sources such as recycled Medicaid payments, Federal money excluded from use as State match, impermissible taxes, and non-bona fide provider-related donations. Impermissible sources do not include patient care or other revenue received from programs such as Medicare or Medicaid to the extent that the program revenue is not obligated to the State as the source of funding.

1.3 DHCS shall reconcile the “Estimated Member Months,” in Exhibit 1, to actual enrollment in HEALTH PLAN(S) for the service periods of July 1, 2019 through June 30, 2020, and July 1, 2020 through December 31, 2020 using actual enrollment figures taken from DHCS records. Enrollment reconciliation will occur on an ongoing basis as updated enrollment figures become available. Actual enrollment figures will be considered final two years after June 30, 2020 and December 31, 2020, respectively. DHCS shall reconcile the “Projected Contribution PMPM,” in Exhibit 1(b), to actual PMPM for HEALTH PLAN(S) for the service period of July 1, 2020 through December 31, 2020 using actual PMPMs that result from the risk adjustment process as reflected in figures taken from DHCS records. PMPM reconciliation will occur on an ongoing basis as the risk adjustment process is finalized. Actual PMPM amounts will be considered final two years after December 31, 2020. If reconciliation results in an increase to the total amount necessary to fund the nonfederal share of the payments described in Sub-Section 2.2, the GOVERNMENTAL FUNDING ENTITY agrees to transfer any additional funds necessary to cover the difference. If reconciliation results in a decrease to the total amount necessary to fund the nonfederal share of the payments described in Sub-Section 2.2, DHCS agrees to return the unexpended funds to the GOVERNMENTAL FUNDING ENTITY. If

DHCS and the GOVERNMENTAL FUNDING ENTITY mutually agree, amounts due to or owed by the GOVERNMENTAL FUNDING ENTITY may be offset against future transfers.

2. Acceptance and Use of Transferred Funds

2.1 DHCS shall exercise its authority under section 14164 of the Welfare and Institutions Code to accept funds transferred by the GOVERNMENTAL FUNDING ENTITY pursuant to this Agreement as IGTs, to use for the purpose set forth in Sub-Section 2.2.

2.2 The funds transferred by the GOVERNMENTAL FUNDING ENTITY pursuant to Section 1 and Exhibit 1 of this Agreement shall be used to fund the non-federal share of Medi-Cal Managed Care actuarially sound capitation rates described in section 14301.4(b)(4) of the Welfare and Institutions Code as reflected in the contribution PMPM and rate categories reflected in Exhibit 1. The funds transferred shall be paid, together with the related Federal Financial Participation, by DHCS to HEALTH PLAN(S) as part of HEALTH PLAN(S)' capitation rates for the service periods of July 1, 2019 through June 30, 2020, and July 1, 2020 through December 31, 2020, in accordance with section 14301.4 of the Welfare and Institutions Code.

2.3 DHCS shall seek Federal Financial Participation for the capitation rates specified in Sub-Section 2.2 to the full extent permitted by federal law.

2.4 The parties acknowledge that DHCS will obtain any necessary approvals from the Centers for Medicare and Medicaid Services.

2.5 DHCS shall not direct HEALTH PLAN(S)' expenditure of the payments received pursuant to Sub-Section 2.2.

3. Assessment Fee

3.1 DHCS shall exercise its authority under section 14301.4 of the Welfare and Institutions Code to assess a 20 percent fee related to the amounts transferred pursuant to Section 1 of this Agreement, except as provided in Sub-Section 3.2. GOVERNMENTAL FUNDING ENTITY agrees to pay the full amount of that assessment in addition to the funds transferred pursuant to Section 1 of this Agreement.

3.2 The 20-percent assessment fee shall not be applied to any portion of funds transferred pursuant to Section 1 that are exempt in accordance with sections 14301.4(d) or 14301.5(b)(4) of the Welfare and Institutions Code. DHCS shall have sole discretion to determine the amount of the funds transferred pursuant to Section 1 that will not be subject to a 20 percent fee. DHCS has determined that \$0.00 of the transfer amounts will not be assessed a 20 percent fee, subject to Sub-Section 3.3.

3.3 The 20-percent assessment fee pursuant to this Agreement is non-refundable and shall be wired to DHCS separately from, and simultaneous to, the transfer amounts made under Section 1 of this Agreement. If, at the time of the reconciliation performed pursuant to Sub-Section 1.3 of this Agreement, there is a change in the amount transferred that is subject to the 20-percent assessment in accordance with Sub-Section 3.1, then a proportional adjustment to the assessment fee will be made.

4. Amendments

4.1 No amendment or modification to this Agreement shall be binding on either party unless made in writing and executed by both parties.

4.2 The parties shall negotiate in good faith to amend this Agreement as necessary and appropriate to implement the requirements set forth in Section 2 of this Agreement.

5. Notices. Any and all notices required, permitted or desired to be given hereunder by one party to the other shall be in writing and shall be delivered to the other party personally or by United States First Class, Certified or Registered mail with postage prepaid, addressed to the other party at the address set forth below:

To the GOVERNMENTAL FUNDING ENTITY:

Paul Duncan, Fire Chief
South Lake County Fire Protection District
21095 State Highway 175
P.O. Box 1360
Middletown, CA 95461
Paul.Duncan@fire.ca.gov

With copies to:

Gloria Fong, Staff Services Analyst
South Lake County Fire Protection District
21095 State Highway 175
P.O. Box 1360
Middletown, CA 95461
Gloria.Fong@fire.ca.gov

Jeff Ingram, Director, FP&A
Partnership Health Plan of California
4665 Business Center Drive
Fairfield, CA 94534
jingram@partnershiphp.org

To DHCS:

Sandra Dixon
California Department of Health Care Services
Capitated Rates Development Division
1501 Capitol Ave., Suite 71-4002
MS 4413
Sacramento, CA 95814
Sandra.Dixon@dhcs.ca.gov

6. Other Provisions

6.1 This Agreement contains the entire Agreement between the parties with respect to the Medi-Cal payments described in Sub-Section 2.2 of this Agreement that are funded by the GOVERNMENTAL FUNDING ENTITY, and supersedes any previous or contemporaneous oral or written proposals, statements, discussions, negotiations or other agreements between the GOVERNMENTAL FUNDING ENTITY and DHCS relating to the subject matter of this Agreement. This Agreement is not, however, intended to be the sole agreement between the parties on matters relating to the funding and administration of the Medi-Cal program. This Agreement shall not modify the terms of any other agreement, existing or entered into in the future, between the parties.

6.2 The non-enforcement or other waiver of any provision of this Agreement shall not be construed as a continuing waiver or as a waiver of any other provision of this Agreement.

6.3 Sections 2 and 3 of this Agreement shall survive the expiration or termination of this Agreement.

6.4 Nothing in this Agreement is intended to confer any rights or remedies on any third party, including, without limitation, any provider(s) or groups of providers, or any right to medical services for any individual(s) or groups of individuals. Accordingly, there shall be no third party beneficiary of this Agreement.

6.5 Time is of the essence in this Agreement.

6.6 Each party hereby represents that the person(s) executing this Agreement on its behalf is duly authorized to do so.

7. State Authority. Except as expressly provided herein, nothing in this Agreement shall be construed to limit, restrict, or modify the DHCS’ powers, authorities, and duties under Federal and State law and regulations.

8. Approval. This Agreement is of no force and effect until signed by the parties.

9. Term. This Agreement shall be effective as of July 1, 2019 and shall expire as of June 30, 2023 unless terminated earlier by mutual agreement of the parties.

SIGNATURES

IN WITNESS WHEREOF, the parties hereto have executed this Agreement, on the date of the last signature below.

THE SOUTH LAKE COUNTY FIRE PROTECTION DISTRICT:

By: _____ Date: _____
Paul Duncan, Fire Chief

THE STATE OF CALIFORNIA, DEPARTMENT OF HEALTH CARE SERVICES:

By: _____ Date: _____
Rafael Davtian, Division Chief, Capitated Rates Development Division

Exhibit 1

Health Plan:	Partnership Health Plan of California		
Rating Region:	Northern Region		
Service Period	7/2019-12/2019		
Rate Category	Contribution PMPM	Estimated Member Months*	Estimated Contribution (Non-Federal Share)
Child - non MCHIP	\$ 0.01	490,976	\$ 4,910
Child - MCHIP	\$ 0.01	207,593	\$ 2,076
Adult - non MCHIP	\$ 0.06	259,978	\$ 15,599
Adult - MCHIP	\$ 0.02	5,457	\$ 109
ACA Optional Expansion	\$ 0.01	559,701	\$ 5,597
SPD	\$ 0.16	139,257	\$ 22,281
SPD/Full-Dual	\$ 0.03	234,562	\$ 7,037
BCCTP	\$ 0.28	924	\$ 259
LTC	\$ 0.56	368	\$ 206
LTC/Full Dual	\$ 0.35	11,043	\$ 3,865
Whole Child Model	\$ 0.30	26,480	\$ 7,944
Estimated Total		1,936,339	\$ 69,883

Health Plan:	Partnership Health Plan of California		
Rating Region:	Northern Region		
Rating Region:	1/2020-6/2020		
Rate Category	Contribution PMPM	Estimated Member Months*	Estimated Contribution (Non-Federal Share)
Child - non MCHIP	\$ 0.02	501,577	\$ 10,032
Child - MCHIP	\$ 0.01	212,075	\$ 2,121
Adult - non MCHIP	\$ 0.05	264,310	\$ 13,216
Adult - MCHIP	\$ 0.02	5,548	\$ 111
ACA Optional Expansion	\$ 0.01	564,831	\$ 5,648
SPD	\$ 0.15	140,806	\$ 21,121
SPD/Full-Dual	\$ 0.03	239,061	\$ 7,172
BCCTP	\$ 0.27	935	\$ 252
LTC	\$ 0.50	378	\$ 189
LTC/Full Dual	\$ 0.31	11,274	\$ 3,495
Whole Child Model	\$ 0.27	26,730	\$ 7,217
Estimated Total		1,967,525	\$ 70,574

Exhibit 1(b)

Health Plan:	Partnership Health Plan of California		
Rating Region:	Northern Region		
Rating Region:	7/2020 - 12/2020		
Rate Category	Projected Contribution PMPM**	Estimated Member Months*	Estimated Contribution (Non-Federal Share)
Child - non MCHIP	\$ 0.02	551,020	\$ 11,020
Child - MCHIP	\$ 0.01	232,981	\$ 2,330
Adult - non MCHIP	\$ 0.05	292,648	\$ 14,632
Adult - MCHIP	\$ 0.03	6,143	\$ 184
ACA Optional Expansion	\$ 0.01	635,916	\$ 6,359
SPD	\$ 0.15	146,644	\$ 21,997
SPD/Full-Dual	\$ 0.03	248,471	\$ 7,454
BCCTP	\$ 0.27	1,043	\$ 282
LTC	\$ 0.52	401	\$ 209
LTC/Full Dual	\$ 0.33	12,175	\$ 4,018
Whole Child Model	\$ 0.29	28,638	\$ 8,305
Estimated Total		2,156,080	\$ 76,790

* Note that Estimated Member Months are subject to variation, and the actual total Contribution (Non-Federal Share) may differ from the amount listed here.

** Note that Projected Contribution PMPMs are subject to change based on the risk adjustment process of rate development, and the actual total Contribution (Non-Federal Share) may differ from the amount listed here.

HEALTH PLAN-PROVIDER AGREEMENT

Partnership HealthPlan of California and South Lake County Fire Protection District

This Amendment is made this 21st day of August, by and between Partnership HealthPlan of California, a County Organized Health System hereinafter referred to as "PLAN", and **South Lake County Fire Protection District**, hereinafter referred to as "PROVIDER".

RECITALS:

WHEREAS, PLAN and PROVIDER have previously entered into an Agreement effective June 1, 2015;

WHEREAS, Section 9.2 of such Agreement provides for amending such Agreement;

WHEREAS, PLAN has been created by its Boards of Supervisors to negotiate exclusive contracts with the California Department of Health Care Services and to arrange for the provision of PLAN covered health care services to PLAN beneficiaries in Lake County and PLAN is a public entity, created pursuant to Welfare and Institutions Code 14087.54 and County Code Chapters 7.2, County Code Chapters 34, County Code Chapters 2.40, County Code Chapters 2.0, 8.69, and County Code Chapters 2.0.

WHEREAS, South Lake County Fire Protection District, is a Fire District in Lake County, California, that provides fire suppression services and emergency medical services, and emergency transport services; and

WHEREAS, PLAN and PROVIDER desire to amend the Agreement to provide for Medi-Cal managed care capitation rate increases to PLAN as a result of intergovernmental transfers ("IGTs") from South Lake County Fire Protection District to the California Department of Health Care Services ("State DHCS") to maintain the availability of PLAN covered health care services to PLAN beneficiaries.

NOW, THEREFORE, PLAN and PROVIDER hereby agree as follows:

Attachment D to the Agreement is hereby deleted in its entirety and replaced with a new Attachment D as set forth herein and is incorporated into the Agreement.

IGT MEDI-CAL MANAGED CARE CAPITATION INCREASES

1. IGT Capitation Increases to PLAN

A. Payment

Should PLAN receive any Medi-Cal managed care capitation rate increases from State DHCS where the nonfederal share is funded by the **GOVERNMENTAL FUNDING ENTITY** South Lake County Fire Protection District effective July 1, 2019 for Intergovernmental Transfer Medi-Cal Managed Care Increases ("IGT MMCIs"), PLAN shall pay to PROVIDER the amount of the IGT MMCIs received from State DHCS, in accordance with paragraph 1.E below regarding the form and timing of Local Medi-Cal Managed Care ("LMMC") IGT Payments. LMMC IGT Payments paid to PROVIDER shall not replace or supplant any other amounts paid or payable to PROVIDER by PLAN.

B. Health Plan Retention

(1) Medi-Cal Managed Care Seller's Tax

The PLAN shall be responsible to pay the applicable State Agency pursuant to the Revenue and Taxation Code Section 6175 relating to any IGT MMCIs.

(2) The PLAN shall retain up to ten percent (10%) administrative fee based on the total amount of the IGT MMCIs received from DHCS for PLAN'S administrative costs. Each provider's share of the 10% fee shall be calculated based on that provider's proportionate share of the LMMC IGT payments made by Plan in the PROVIDER'S County.

C. Form and Timing of Payments

PLAN agrees to pay LMMC IGT Payments to PROVIDER in the following form and according to the following schedule:

(1) PLAN agrees to pay the LMMC IGT Payments to PROVIDER using the same mechanism through which compensation and payments are normally paid to PROVIDER (e.g., electronic transfer).

(2) PLAN will pay the LMMC IGT Payments to PROVIDER no later than thirty (30) calendar days after receipt of the IGT MMCIs from State DHCS.

D. Consideration

(1) As consideration for the LMMC IGT Payments, PROVIDER shall use the LMMC IGT Payments for the following purposes and shall treat the LMMC IGT Payments in the following manner:

(a) The LMMC IGT Payments shall represent compensation for Medi-Cal PLAN services rendered to Medi-Cal PLAN members by PROVIDER during the State fiscal year to which the LMMC IGT Payments apply.

(2) If the retained LMMC IGT Payments, if any, are not used by PROVIDER in the State fiscal year received, retention of funds by PROVIDER will be established by demonstrating that the retained earnings account of PROVIDER at the end of any State fiscal year in which it received payments based on LMMC IGT Payments funded pursuant to the Intergovernmental Agreement, has increased over the unspent portion of the prior State fiscal year's balance by the amount of LMMC IGT Payments received, but not used.

(3) Both parties agree that none of these funds, either from the **GOVERNMENTAL FUNDING ENTITY** South Lake County Fire Protection District or federal matching funds will be recycled back to the **GOVERNMENTAL FUNDING ENTITY** South Lake County Fire Protection District general fund, the State, or any other intermediary organization. Payments made by the health plan to providers under the terms of this Amendment constitute patient care revenues.

E. Cooperation Among Parties

Should disputes or disagreements arise regarding the ultimate computation or appropriateness of any aspect of the LMMC IGT Payments, PROVIDER and PLAN agree to work together in all respects to support and preserve the LMMC IGT Payments to the full extent possible on behalf of the safety net in Lake County.

F. Reconciliation

Within one hundred twenty (120) calendar days after the end of each of PLAN's fiscal years in which LMMC IGT Payments were made to PROVIDER, PLAN shall perform a reconciliation of the LMMC IGT Payments transmitted to the PROVIDER during the preceding fiscal year to ensure that the supporting amount of IGT MMCI were received by PLAN from State DHCS. PROVIDER agrees to return to PLAN any overpayment of LMMC IGT Payments made in error to PROVIDER within thirty (30) calendar days after receipt from PLAN of a written notice of the overpayment error, unless PROVIDER submits a written objection to PLAN. Any such objection shall be resolved in accordance with the dispute resolution processes set forth in Section 10.3 of the Agreement. The reconciliation processes established under this paragraph are distinct from the indemnification provisions set forth in Section J below. PLAN agrees to transmit to the PROVIDER any underpayment of LMMC IGT Payments within thirty (30) calendar days of PLAN's identification of such underpayment.

G. Indemnification

PROVIDER shall indemnify PLAN in the event DHCS or any other federal or state agency recoups, offsets, or otherwise withholds any monies from or fails to provide any monies to PLAN, or PLAN is denied any monies to which it otherwise would have been entitled, as a direct result of the LMMC IGT arising from the Intergovernmental Agreement. Recovery by PLAN pursuant to this section shall include, but not be limited to, reduction in future LMMC IGTs paid to PROVIDER in an amount equal to the amount of MMCI payments withheld or recovered from PLAN, or by an offset of any other amounts owed by PLAN to PROVIDER, including but not limited to payments for direct service rendered.

Remittance Information

The IGT-funded payments made by the PLAN pursuant to this Amendment only, shall be mailed to the PROVIDER at the address set forth below:

Greg Bertelli, Fire Chief
South Lake County Fire Protection District

2. Term

The term of this Amendment shall commence on July 1, 2019 through June 30, 2024. PHC reserves the right to immediately terminate this IGT Amendment prior to June 30, 2024, if DHCS suspends or discontinues the IGT funding described in this Amendment. PHC will promptly provide formal notice to the provider upon said suspension or discontinuation.

All other terms and provisions of said Agreement shall remain in full force and effect so that all rights, duties and obligations, and liabilities of the parties hereto otherwise remain unchanged; provided, however, if there is any conflict between the terms of this Amendment and the Agreement, then the terms of this Amendment shall govern.

SIGNATURES

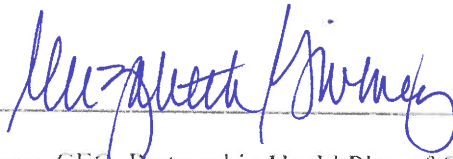
HEALTH PLAN:  Date: 8/21/19
By: Elizabeth Gibboney, CEO Partnership HealthPlan of California

PROVIDER:  Date: 7/16/19
By: Greg Bertelli, Fire Chief, South Lake County Fire Protection District

Final Agreement: 2019-20 Rate Range Program

Fri 8/14/2020 10:30 AM

South Lake County Fire Protection District:

Due to the operational impacts of COVID-19, DHCS has revised the previously sent "draft" agreements (originally sent in April 2020). The following updates were made:

- Member Month estimates as of 6/2020. Includes a 2% buffer on estimated Member Months for the January 1, 2020 through December 31, 2020 time period.
- Revised final health plan capitation rates
- Federal financial participation percentages, which reflects the Families First Coronavirus Response Act (FFCRA).

Attached is the final Rating Period 2019-20 Rate Range Program agreement between DHCS and the governmental funding entity. Section 3.2, Exhibit 1 and Exhibit 1(b) incorporate the above updates. The department signer was also updated. No other language changes were made.

Please obtain the necessary signature(s) on **five (5)** originally signed copies of the agreement, and send the signed agreements to me for execution on or before **October 16, 2020** at:

Sandra Dixon
Capitated Rated Development
Division California Department of
Health Care Services 1501 Capitol
Avenue, MS 4413
Sacramento, CA 95814

Do not submit any agreements/contracts between the health plans and providers related to the Rating Period 2019-20 Rate Range Program. If you have any questions, please contact me via e-mail or at (916) 420-5730.

Sandra Dixon
Department of Health Care
Services Capitated Rates
Development Division

Sent: Friday, May 8, 2020 2:44 PM

Subject: Delay: Approval and Draft Agreement: 2019-20 Rate Range

Program Dear South Lake County Fire Protection District,

Due to the operational impacts of COVID-19, we estimate the 2019-20 Rate Range Program **final** agreements will be delayed for signature until September 2020. Note: this timeline is subject to change.

We apologize for any inconvenience may cause and appreciate your understanding.

Sent: Tuesday, April 21, 2020 11:27 AM

Subject: Approval and Draft Agreement: 2019-20 Rate Range

Program Hello, South Lake County Fire Protection District:

Welfare and Institutions Code, sections 14164 and 14301.4, authorize the Department of Health Care Services (DHCS) to implement a voluntary Rate Range Program relating to the Medi-Cal managed care capitation rate ranges. The funding amounts under the voluntary Rate Range Program are the nonfederal share of the difference between the Medi-Cal managed care plans' contracted capitation rates and the top of the plans' actuarially sound rate range, as determined by the DHCS. The funds voluntarily transferred by the governmental funding entities (counties, cities, special purpose districts, state university teaching hospitals, or any other political subdivision of the state) to DHCS for this program shall be used to fund the nonfederal share of Medi-Cal managed care actuarially sound capitation rates described in section 14301.4(b)(4) of the Welfare and Institutions Code. These funds shall be paid, together with the related federal financial participation, by DHCS to Medi-Cal managed care plans as part of capitation rates for the rating period of July 1, 2019 through December 31, 2020.

DHCS received your letter(s) of interest (see attached) regarding the Rating Period 2019-20 (July 1, 2019 – December 31, 2020) Voluntary Rate Range Program. Subsequent to our letters sent to plans in December 2019, DHCS adjusted the available rate range funding calculation to reflect updated member month estimates and capitation rates; your updated estimated contribution amount is \$229,091. Please refer to the attached document titled "Intergovernmental Agreement Regarding Transfer of Public Funds" for the actual contribution per member per month amounts by rate category. In accordance with Welfare and Institutions Code section 14301.4(d) and 14301.5(b)(4), and pursuant to the terms of the attached agreement, DHCS has determined that an estimated \$0.00 of the total contribution amount will not be subject to a 20% assessment fee.

Each governmental funding entity that has chosen to participate in the Rating Period 2019-20 Voluntary Rate Range Program must complete the attached draft "Intergovernmental Agreement Regarding Transfer of Public Funds," between the governmental funding entity and DHCS. Complete Section 5 – Notices (individual's name, mailing address and e-mail address), and in the Signature Section, include the name of the governmental funding entity as well as the name and title of the person executing the agreement. Do not, however, sign the agreement at this time. All other sections have been completed by DHCS.

Upon completion, the agreement must be e-mailed to: Sandra.Dixon@dhcs.ca.gov by **May 1, 2020**. The agreement needs to be completed but not signed. After DHCS reviews, we will resend the final agreement to you for signature.

Estimated timeline for the Rating Period 2019-20 Voluntary Rate Range Program:

Completed draft documents (notifications & signature line) submitted by funding entity	5/1/2020
Agreements sent back to funding entity for signatures	5/8/2020
Signed Agreements due to DHCS from funding entity	7/2020
Initial Wiring of Incoming Funds (7/2019 – 6/2020)	1 st quarter of calendar year 2021
Initial Wiring of Incoming Funds (7/2020 – 12/2020)	2 nd /3 rd quarter of calendar year 2021

The anticipated timeline is subject to change, and you will notified via e-mail or letter regarding the actual due dates. If you have any questions, please feel free to contact me by e-mail at Sandra.Dixon@dhcs.ca.gov.

Sandra Dixon
Department of Health Care
Services Capitated Rate
Development Division 916-
345-8269



South Lake County Fire Protection District
— in cooperation with —
California Department of Forestry and Fire Protection

P.O. Box 1360 Middletown, CA 95461 - (707) 987-3089

January 24, 2020

Jennifer Lopez
Division Chief
Capitated Rates Development Division
Department of Health Care Services
1501 Capitol Avenue, MS 4413
P.O. Box 997413
Sacramento, CA 95899-7413

Dear Ms. Lopez:

This letter confirms the interest of South Lake County Fire Protection District, a governmental entity, federal I.D. Number 94-2214592, in working with the Partnership HealthPlan of California (MCP) and California Department of Health Care Services (DHCS) to participate in the Voluntary Rate Range Program, including providing an Intergovernmental Transfer (IGT) to DHCS to be used as a portion of the non-federal share of actuarially sound Medi-Cal managed care capitation rate payments incorporated into the contract between the MCP and DHCS for the periods of July 1, 2019 through June 30, 2020, and July 1, 2020 through December 31, 2020. This is a non-binding letter, stating our interest in helping to finance health improvements for Medi-Cal beneficiaries receiving services in our jurisdiction. The governmental entity's funds are being provided voluntarily, and the State of California is in no way requiring the governmental entity to provide any funding.

South Lake County Fire Protection District is willing to contribute approximately \$229,063 for the Rating Period 2019-20 (July 1, 2019 through December 31, 2020) as negotiated with the MCP. We recognize that, unless a waiver is approved by DHCS, there will be an additional 20-percent assessment fee payable to DHCS on the funding amount, for the administrative costs of operating the voluntary rate range program.

The following individual from our organization will serve as the point of communication between our organization, the MCP and DHCS on this issue:

Gloria Fong
21095 State Highway 175
Middletown, CA 95461
gloria.fong@fire.ca.gov
(707) 987-3089 ext. 3

I certify that I am authorized to sign this certification on behalf of the governmental entity and that the statements in this letter are true and correct.

Sincerely,

SOUTH LAKE COUNTY FIRE PROTECTION DISTRICT

Shana Jones
Fire Chief

RE: 2018-19 Rate Range IGT Payment

Jeff Ingram

Wed 4/8/2020 3:34 PM

Cc: Kamille Gholson

Warning: this message is from an external user and should be treated with caution.

Afternoon,

The 2018-19 Rate Range IGT checks have been printed and mailed, please be on the lookout. Let us know if you have any questions or concerns regarding the amount.

-JI

Jeff Ingram
Director, FP&A
Partnership HealthPlan of California
4665 Business Center Drive, Fairfield, CA 94534
Phone: (707) 863-4227
Our website: www.partnershiphp.org

From: Jeff Ingram
Sent: Wednesday, April 1, 2020 4:04 PM
Cc: Liz Gibboney ; Patti McFarland; Kamille Gholson
Subject: 2018-19 Rate Range IGT Payment

2018-19 IGT Participants,

Please see a communication from our CEO, Liz Gibboney, attached.

-JI

Jeff Ingram
Director, FP&A
Partnership HealthPlan of California
4665 Business Center Drive, Fairfield, CA 94534
Phone: (707) 863-4227
Our website: www.partnershiphp.org

"PHC Securemail Server" made the following annotations.

This email and any attachments are intended for a specific individual and purpose and may be protected by law. If you are not the intended recipient, you should delete this message. Any disclosure or distribution of this message is strictly prohibited.

=====
=====



4665 Business Center Drive
Fairfield, California 94534

April 1, 2020

Dear Partnership HealthPlan of California Provider,

Given the unique circumstances at this time, it's critical that we explore opportunities to get valuable resources into our communities. PHC has made the decision to distribute the 2018-19 Rate Range IGT Program ahead of our cash receipts from DHCS. In addition, PHC is waiving the 3% administrative fee for the 2018-19 cycle in an effort to further maximize the non-federal share for each of the participating entities.

PHC anticipates mailing checks to entities by April 10, 2020.

PHC recognizes the resource constraints caused by the extenuating circumstances of COVID-19 and will continue to seek opportunities to assist providers, where allowable and appropriate.

If you have questions, please contact our Director of Financial Planning & Analysis, Jeff Ingram (jingram@partnershiphp.org).

A handwritten signature in blue ink that reads "Elizabeth R. Gibboney".

Elizabeth R. Gibboney
Chief Executive Officer



South Lake County Fire Protection District
— in cooperation with —
California Department of Forestry and Fire Protection

P.O. Box 1360 Middletown, CA 95461 - (707) 987-3089

BOARD OF DIRECTORS' REGULAR MEETING MINUTES

7:00 P.M., July 21, 2020
Middletown Fire Station, 21095 Highway 175

NON-TIMED ITEMS

A. OPEN MEETING:

- A1. *President Martinelli called meeting to order at 7 p.m.*
- A2. *Pledge of allegiance led by Chief Duncan.*
- A3. *Present: Vice President Jim Comisky, Directors Rob Bostock, Devin Hoberg, and President Madelyn Martinelli, Eric Redford (joined meeting at start of TIMED ITEMS). Also present: Chief Paul Duncan, Battalion Chief Mike Wink, and Board Clerk Gloria Fong.*
- A4. **BOSTOCK/COMISKY MOTION** to approve agenda. *AYES: Hoberg, Bostock, Comisky, Martinelli. NOES: None. MOTION CARRIED.*

B. CITIZENS' INPUT: None.

C. COMMUNICATIONS:

C1. Reports:

C1.1. Fire Sirens

In their absence, Chief Duncan reports the three days they've been hope was hugely successful.

C1.2. SL Fire Safe Council: No report

C1.3. Volunteer Firefighters' Association

Association President Fenk reports PCFs Chase and Lopez took vehicle up to Oregon for Type 6 fitting, and new Type 3 engine just branded is at Konocti for some services and numbering.

C1.3.1. Introduction and Badge Pinning of Paid Call Firefighters

Newly recruits, Caden DeLong, Logan Hildebrand, Shelby Myers, and Nik Vargas, graduated from Napa program and their families are welcomed.

Pride and what it means to be part of proudest organization and profession, family of brotherhood and sisterhood to serve community is highest calling. Chief Duncan very proud with everyone on completion of academy with several are going on to summertime Cal Fire program. He thanked families, giving them their time to serve the community.

PCF Ron Chase knows all four have gone through a lot with COVID situation each doing what they can to get through.

PCF Captain Cory Smith is proud of them, and they will to be part of a family who stick together and provide for safety first.

On behalf of the Board, Director Comisky thanked all and welcome them to long journey, whom he himself has served 44 years.

C1.4. Chief's Report

For North Division a successful meeting was held at the Boatique Winery on June 25th.

For camp operations, 4 crews are available at Konocti. This may change based on a new mandate to release inmates with less than 180 days left on their sentence.

For South Lake operations, District took delivery of the new M6311. It'll be in service after a couple of identified issues are dealt with.

The PCF team is taking the Type 6 Cab and Chassis to Medford, Oregon by July 27th. Scheduled completion is by August 27th.

The Association purchased Type 3 Engine from Calistoga Fire. It is being painted, then will be lettered, pump tested and serviced.

On the maintenance side, WT6011 is receiving some new water valves, E6031 is being maintenance and OES359 is having a defective injector replaced.

On the facility side, electrical safety improvements have been completed at Station 64 and an electrical subpanel at 63 that was too small and sparking, required replacement. Station 60 roll up doors have been a big challenge recently. Several broken motors and windows were repaired. Station 60 is due to get pavement sealer in August.

Our Fire Family from Middletown Station 31 are now temporarily working out of Station 60 during their floor repair, and asbestos abatement.

The "House of Bargains" Thrift Shop re-opens Tuesday, July 14th.

A PCF who has been assisting Gloria while plans are made to hire a new office technician.

Several PCF's are working on their CAL FIRE Firefighter Basic "Bridge" Training.

An Engineer we have, who is a Coast Guard Reservist, received orders to return to active duty in Rhode Island for three years because of COVID-19.

We are in process to hire Permanent and Limited Term FFII Paramedics.

A total of 22 first responders responded to a recent bariatric trauma and rescue, performing critical tasks, which made rescue a success. In spite of massive blood loss and significant trauma, Paramedics, Reach Crew and Hospital staff successfully saved this man's life.

C1.5. Financial Report

Gloria reports:

District data is provided instead of Wittman reports, which are unavailable, because billing delayed June's closure.

She attended GoToMeeting Lake County Fire Miasha Rivas put together. She did an excellent job.

She asked the Board to be prepared to see the warrant list reports look different, as she continues to work on one that isn't as cluttered.

Reports of direct charges were just received.

Board of Supervisors approved all the fire districts' capital fire facility plans we submitted in March and their resolution attached.

C2. Directors Activity and Committee Report

Director Bostock has no activity to report.

Director Comisky reports there's been no conclusion for repeater system and more to follow for emergency alerting and weather service, he completed ethics training, and as of Saturday, he is retired again.

Director Hoberg has no district business to report.

Director Redford joined the meeting and has no activity to report.

Director Martinelli video-taped siren going off for Battalion Chief Wink.

TIMED ITEMS

D. REGULAR ITEM:

- D1. **TABLED FROM 6/16/2020 MEETING:** Consideration for Resolution No 2020-21 01 A Resolution Establishing Fiscal Year 2020-2021 Appropriations Limit. Placed on agenda by Gloria Fong.

Measure L ballot provides for increase using consumer price index (CPI). What it didn't establish is a methodology. The ballot didn't include which CPI to use, such as urban wage earners (CPI-U) or clerical workers (CPI-W) population group. It also didn't identify the period. Overall whether January to January or December to December has the same net escalation, as provided in attached table. With these, the appropriations can continue to be set using Department of Finance income and population increases for the County of Lake area and sets base for each year thereafter.

BOSTOCK/COMISKY MOTION to approve appropriations limit utilizing urban group 12-month December to December. **AYES:** Redford, Comisky, Bostock, Hoberg, Martinelli. **NOES:** None. **MOTION CARRIED.**

- D2. Consideration for Resolution No. 2019-20-12, A Resolution Requesting the Board of Supervisors and the Registrar of Voters consent to and order the consolidation with such other elections as may be held on Tuesday, November 3, 2020, anywhere within the territory of the district for Appropriations Limit Override beginning with fiscal year 2021-2022. Placed on agenda by Gloria Fong. Placed on agenda by

In prior year's, the appropriations limit override provided 1.25 million increase, which is option 1 on the resolution. Prior to this, the override amount was \$950,000.

With Measure L passage, the appropriations limit override includes the Measure L amount, which is option 2.

COMISKY/BOSTOCK MOTION to approve D2 with option 2 as submitted. **AYES:** Hoberg, Redford, Bostock, Comisky Martinelli. **NOES:** None. **MOTION CARRIED.,**

- D3. Update on telephone consultation with Legal Counsel Bill Adams held Monday July 20th regarding the DA (Development Agreement) between the Guenoc Development and the County of Lake, which contain items that will and could affect South Lake County Fire Protection District, specifically, DA Sections 2.23, 2.58, 7.4, 12.3 and 12.4. Placed on agenda by Chief Duncan and Battalion Chief Wink.

This information is provided for discussion with no action to be taken. Chiefs reached out to counsel as part of proposed agreement between Guenoc and County of Lake.

The Board of Supervisor approved agreement with four to one vote.

Chiefs reached out to counsel for proposal as part of the proposed agreement for Guenoc project, which was approved by County Board of Supervisors vote 4 to 1.

On the agreement with the Fire District, there were a few areas of concern that Chiefs raised to legal counsel and got direction. To Section 2.23 Emergency Response Center there is question on ownership of land and how Fire District will operate it and it will be operated under perpetual easement and not change to this section. With section 7.4 want to make sure Measure is codified and able to assess Measure L going forward, amended with addition of sentence to end reads "these limitations exclude the continued special tax levy Measure L approved by voters of the district November 2018. In 12.3 Emergency Response Center's it didn't address what on-going cost and is amended "and on-going maintenance cost".

The \$1 per square foot will be used as credit towards their cost of building the Emergency Response Center and all the equipment. All property tax, AB formula and Measure L will all be paid.

- D4. Discussion for South Lake County Fire Protection District to retain Legal Counsel Scott Ferguson, from San Francisco based Law Firm of Jones Hall, who specializes in public entity type Bonds and similar items, and whose involvement and input to Bonds process, intended to fund building of the Fire Station and purchasing of all equipment is recommended and requested by Guenoc Development Team and all legal service expenses to be reimbursed by the Guenoc Development Team. Placed on agenda by Battalion Chief Wink.

The Guenoc Development Team is looking at Mello Roos bonds and the expert from California, Legal Counsel Scott Ferguson from San Francis based Law Firm of Jones Hall is whom they are considering. He only works for municipalities and not private entities. His expenses will be reimbursed by the Team and an agreement to follow between them for this.

Comisky reminded the Board we approved a CFD and approved Measure L and can also include the Mello Roos under 12.4 of the previous discussed item.

Attorney Bill Adams unequivocally recommends Scott Ferguson to provide assistance.

COMISKY/HOBERG MOTION *to have staff move forward and bring back agreement for Board to review. AYES: Bostock, Redford, Hoberg, Comisky, Martinelli*

- D5. Situational awareness briefing about agricultural development within the South Lake County Fire Protection District that may present challenges for Emergency Ingress and Egress. Placed on agenda by Battalion Chief Wink.

Battalion Chief Wink has had dialogue before with Board about the growing number of adult cannibas being developed around the county. The County Board of Supervisors determined this to be agricultural process and exempt from fire mitigation fee. Per fire code and public resource codes, it doesn't have any improvement to ingress or egress, where we may be called to upon emergency response on an unimproved road, not because of the product but because it is likely to happen. This is about 100,000 plus square feet the Fire District is to protect like anything else that doesn't pay fire mitigation fees and we are uncertain how it applies to property tax rolls.

Director Comisky feels we as Fire District need to aggressively approach the County because it is different nature than grapes or pears. Chief Duncan is in agreement.

President Martinelli appointed to a situational awareness on agricultural development ad hoc committee, Directors Redford and Comisky along with Chief Duncan.

E. CONSENT CALENDAR:

E1. Minutes presented:

E1.1. June 16, 2020 – Regular Meeting

E2. Warrants presented:

E2.1. July – preliminary

E2.2. June – corrected

HOBURG/COMISKY MOTION to approve consent calendar. *AYES: Bostock, Redford, Comisky, Hoberg, Martinelli. NOES: None. MOTION CARRIED.*

F. **BOSTOCK/HOBERG MOTION** to adjourn the meeting at 8:35 p.m. All members in attendance are in favor of the motion.

Respectfully submitted by: _____
Gloria Fong
Board Clerk

READ AND APPROVED BY: _____
MADelyn MARTINELLI
President – Board of Directors

**South Lake County
Fire Protection District
Cost Accounting Management System
Invoice Audit Trail**

*Detail Report by Vendor, Invoice
Run Date: 08/14/2020 06:44:37pm By: GF
Fiscal Year: 2021*

Selection Criteria

Select Inv Batch No
08/18/20

Report Template

*AP Invoice Report Board Warrant List
\\Southlake\Lsladmin\Wincams\Lslfiles\Report\Criteria\AP Invoice Report Board Warrant List.rst*

Voucher No	Vendor Name	Line Item Description	Budget Exp Acct	Merchant Vendor Name	Line Net Amt	Req No / Descr 2
ARBA001 VENDOR: ARBA						
8518SEP2020	INVOICE: GROUP LIFE FOR PCFS	08/03/20 STATUS: Printed				
10124		SEP 2020 ATKINS	357-9557-795-03-30-G		8.32	
10124		SEP 2020 BULLOCK	357-9557-795-03-30-G		8.32	
10124		SEP 2020 CHASE	357-9557-795-03-30-G		8.32	
10124		SEP 2020 COLLINS	357-9557-795-03-30-G		8.32	
10124		SEP 2020 COSTA	357-9557-795-03-30-G		8.32	
10124		SEP 2020 DANIELS	357-9557-795-03-30-G		8.32	
10124		SEP 2020 DELONG	357-9557-795-03-30-G		8.32	
10124		SEP 2020 EMERSON	357-9557-795-03-30-G		8.32	
10124		SEP 2020 FANUCCHI	357-9557-795-03-30-G		8.32	
10124		SEP 2020 FENK	357-9557-795-03-30-G		8.32	
10124		SEP 2020 FLEENAR	357-9557-795-03-30-G		8.32	
10124		SEP 2020 FRAYER	357-9557-795-03-30-G		8.32	
10124		SEP 2020 HESS	357-9557-795-03-30-G		8.32	
10124		SEP 2020 HILDEBRAND	357-9557-795-03-30-G		8.32	
10124		SEP 2020 LANNING	357-9557-795-03-30-G		8.32	
10124		SEP 2020 LEUZINGER	357-9557-795-03-30-G		8.32	
10124		SEP 2020 LIBBY	357-9557-795-03-30-G		8.32	
10124		SEP 2020 LOPEZ	357-9557-795-03-30-G		8.32	
10124		SEP 2020 MCGEE	357-9557-795-03-30-G		8.32	
10124		SEP 2020 MIINCH	357-9557-795-03-30-G		8.32	
10124		SEP 2020 MYERS	357-9557-795-03-30-G		8.32	
10124		SEP 2020 NEWSOM	357-9557-795-03-30-G		8.32	
10124		SEP 2020 PARROTT	357-9557-795-03-30-G		8.32	
10124		SEP 2020 RYON	357-9557-795-03-30-G		8.32	
10124		SEP 2020 SMITH	357-9557-795-03-30-G		8.32	
10124		SEP 2020 TOTAGRANDE	357-9557-795-03-30-G		8.32	
10124		SEP 2020 VARGAS	357-9557-795-03-30-G		8.32	
10124		JUL & AUG 2020 ZIENTEK	357-9557-795-03-30-G		-16.64	
* 8518SEP2020 Subtotal					208.00	
** ARBA001 Subtotal (1 Invoice)					208.00	
AT&T001 VENDOR: AT&T						
15179416	INVOICE: TELEPHONE CHGS	08/13/20 STATUS: Printed				
10125		Sta 64 ME 07/12/20	357-9557-795-30-00-T4		22.02	
10125		Sta 62 ME 07/12/20	357-9557-795-30-00-T2		48.51	
10125		Sta 63 ME 07/12/20	357-9557-795-30-00-T3		48.53	
10125		Sta 60 ME 07/12/20	357-9557-795-30-00-T0		167.67	
10125		FS Bldg ME 07/12/20	357-9557-795-30-00-TF		20.37	
* 15179416 Subtotal					307.10	
** AT&T001 Subtotal (1 Invoice)					307.10	
CALL001 VENDOR: CALLAYOMI CO WATER DISTRICT						
80 072920	INVOICE: WATER	08/04/20 STATUS: Printed				
10126		STA 60 ME 7/29/20 (121110)	357-9557-795-30-00-W0		1,126.37	
* 80 072920 Subtotal					1,126.37	
81 072920	INVOICE: WATER	08/04/20 STATUS: Printed				
10126		FS BLDG ME 7/29/20 (166)	357-9557-795-30-00-WF		33.93	
* 81 072920 Subtotal					33.93	
** CALL001 Subtotal (2 Invoices)					1,160.30	
COUN002 VENDOR: COUNTY OF LAKE SOLID WASTE						
04-00416710	INVOICE: GARBAGE REMOVAL	07/22/20 STATUS: Printed				
10127		FS BLDG GARBAGE REMOVAL	357-9557-795-30-00-GF		52.53	

Voucher No	Vendor Name	Line Item Description	Budget Exp Acct	Merchant Vendor Name	Line Net Amt	Req No / Descr 2
COUN002 VENDOR: COUNTY OF LAKE SOLID WASTE						
04-00416710	INVOICE: GARBAGE REMOVAL	07/22/20 STATUS: Printed				
10127		STA 31 GARBAGE REMOVAL	357-9557-795-30-00-GA		52.53	
* 04-00416710 Subtotal					105.06	
** COUN002 Subtotal (1 Invoice)					105.06	
EMP001 VENDOR: EMPIRE SCBA & SUPPLIES INC						
13596	INVOICE: REPL EXPIRING SCBA B	07/22/20 STATUS: Printed				
10129		STA 60 REPL EXPIRING SCBA BOTTLES	357-9557-795-38-00-60		6,993.75	
10129		STA 62 REPL EXPIRING SCBA BOTTLES	357-9557-795-38-00-62		6,993.75	
10129		STA 63 REPL EXPIRING SCBA BOTTLES	357-9557-795-38-00-63		6,993.75	
10129		STA 64 REPL EXPIRING SCBA BOTTLES	357-9557-795-38-00-64		6,993.75	
* 13596 Subtotal					27,975.00	
** EMP001 Subtotal (1 Invoice)					27,975.00	
FASI001 VENDOR: FASIS						
FASIS-2021-0256	INVOICE: EMPLOYMENT ASSISTANT	07/30/20 STATUS: Printed				
10130		FY 2020-2021 (26)	357-9557-795-03-30-E		2,549.04	
* FASIS-2021-0256 Subtotal					2,549.04	
** FASI001 Subtotal (1 Invoice)					2,549.04	
JERI001 VENDOR: JERI-CO GARAGE DOORS & OPERATIONS						
16434	INVOICE: BAY DOOR REPAIR	07/14/20 STATUS: Printed				
10131		STA 60 LABOR FRONT DOOR #1	357-9557-795-18-00-60		540.00	
* 16434 Subtotal					540.00	
** JERI001 Subtotal (1 Invoice)					540.00	
LAKE001 VENDOR: LAKE COUNTY EMPLOYEES' ASSN						
HORST SEP 2020	INVOICE: OPEB	09/01/20 STATUS: Printed				
10132		SEP 2020 - HORST DUES	357-9557-795-03-30-R		31.64	
* HORST SEP 2020 Subtotal					31.64	
** LAKE001 Subtotal (1 Invoice)					31.64	
LEAD001 VENDOR: LEADER INDUSTRIES						
116843	INVOICE: 2020 FORD F-550 4X4	06/18/20 STATUS: Printed				
10133		M6311 2020 FORD F-550 4X4 HORTON TY	357-9557-795-62-74-63		235,949.56	PO 20010 M6311
* 116843 Subtotal					235,949.56	
** LEAD001 Subtotal (1 Invoice)					235,949.56	
LIFE001 VENDOR: LIFE ASSIST INC						
1018898	INVOICE: EMS SUPPLIES	07/16/20 STATUS: Printed				
10134		ORDER 08200103-1	357-9557-795-19-40-MS		26.66	
* 1018898 Subtotal					26.66	
1021407	INVOICE: EMS SUPPLIES	07/23/20 STATUS: Printed				
10134		ORDER 57206543-1	357-9557-795-19-40-MS		811.64	
* 1021407 Subtotal					811.64	
1022665	INVOICE: EMS SUPPLIES	07/29/20 STATUS: Printed				
10134		ORDER 57206543-2	357-9557-795-19-40-MS		53.20	
* 1022665 Subtotal					53.20	
1023482	INVOICE: EMS SUPPLIES	07/30/20 STATUS: Printed				
10134		ORDER 08201483-1	357-9557-795-19-40-MS	LIFE ASSIST INC	79.16	
* 1023482 Subtotal					79.16	
** LIFE001 Subtotal (4 Invoices)					970.66	

Voucher No	Vendor Name	Line Item Description	Budget Exp Acct	Merchant Vendor Name	Line Net Amt	Req No / Descr 2
LINC001	VENDOR: LINCOLN LEAVITT INSURANCE AGENCY INC					
89740	INVOICE: INSURANCE-ADDN TO PO 07/29/20	STATUS: Printed				
10135		E6032 1998 NAVISTAR 1HTSDADN7XH599	357-9557-795-15-10-60		618.00	
* 89740 Subtotal					618.00	
89741	INVOICE: INSURANCE-ADDN TO PO 07/29/20	STATUS: Printed				
10135		M6311 2020 FORD 1FDUF5HT6LDA04350	357-9557-795-15-10-63		1,256.00	
* 89741 Subtotal					1,256.00	
89742	INVOICE: INSURANCE 07/29/20	STATUS: Printed				
10135		STA 60	357-9557-795-15-10-60		9,064.29	
10135		STA 62	357-9557-795-15-10-62		1,804.59	
10135		STA 62	357-9557-795-15-10-62		666.33	
10135		STA 63	357-9557-795-15-10-63		1,225.63	
10135		STA 64	357-9557-795-15-10-64		1,401.57	
10135		FS BLDG	357-9557-795-15-10-60		447.41	
10135		STA 60 SCBA	357-9557-795-15-10-60		223.70	
10135		STA 60 VOLUNTEER SHED	357-9557-795-15-10-60		355.42	
10135		TRNG TOWER	357-9557-795-15-10-60		1,203.06	
10135		STA 60 CRIME CVG	357-9557-795-15-10-60		590.00	
10135		STA 60 PORTABLE EQT CVG	357-9557-795-15-10-60		1,549.00	
10135		E6011	357-9557-795-15-10-60		425.00	
10135		WT6011	357-9557-795-15-10-60		418.00	
10135		STA 60 SONOMA KITCHEN	357-9557-795-15-10-60		44.00	
10135		E6221	357-9557-795-15-10-62		454.00	
10135		SC6201	357-9557-795-15-10-62		69.00	
10135		E6321	357-9557-795-15-10-63		454.00	
10135		E6421	357-9557-795-15-10-64		454.00	
10135		U6421	357-9557-795-15-10-64		396.00	
10135		E6061	357-9557-795-15-10-60		853.00	
10135		U6221	357-9557-795-15-10-62		460.00	
10135		U6421	357-9557-795-15-10-64		460.00	
10135		E6421	357-9557-795-15-10-64		290.00	
10135		WT6411	357-9557-795-15-10-64		647.00	
10135		STA 60 EMS TRAILER	357-9557-795-15-10-60		42.00	
10135		SC6201	357-9557-795-15-10-62		286.00	
10135		ADMIN	357-9557-795-15-10-60		324.00	
10135		U6321	357-9557-795-15-10-63		345.00	
10135		E6031	357-9557-795-15-10-60		735.00	
10135		STA 60 DUMP TRAILER	357-9557-795-15-10-60		50.00	
10135		STA 60 OES359	357-9557-795-15-10-60		769.00	
10135		R6031	357-9557-795-15-10-60		674.00	
10135		M6012	357-9557-795-15-10-60		819.00	
10135		M6311	357-9557-795-15-10-63		1,041.00	
10135		M6011	357-9557-795-15-10-60		652.00	
10135		U6011	357-9557-795-15-10-60		325.00	
10135		U6021	357-9557-795-15-10-60		429.00	
10135		M6211	357-9557-795-15-10-62		1,198.00	
10135		STA 60 HIRED EQT AUTO LIABILITY	357-9557-795-15-10-60		96.00	
10135		STA 60 HIRED EQT COMPREHENSIVE	357-9557-795-15-10-60		25.00	
10135		STA 60 HIRED EQT COLLISION	357-9557-795-15-10-60		25.00	
10135		STA 60 NON OWNERSHIP LIABIILTY	357-9557-795-15-10-60		592.00	
10135		STA 60 GENERAL LIABILITY CVG	357-9557-795-15-10-60		3,706.00	
10135		STA 60 MGMT LIABILITY CVG	357-9557-795-15-10-60		6,188.00	
10135		STA 60 EXCESS LIABILITY CVG	357-9557-795-15-10-60		6,995.00	
* 89742 Subtotal					49,271.00	
** LINC001 Subtotal (3 Invoices)					51,145.00	

Voucher No	Vendor Name	Line Item Description	Budget Exp Acct	Merchant Vendor Name	Line Net Amt	Req No / Descr 2
MAHO001	VENDOR: DENNIS MAHONEY					
107	INVOICE: LANDSCAPE MAINT 07/15/20	STATUS: Printed				
10128		STA 60 LANDSCAPE MAINT 06/18/20	357-9557-795-18-00-60		50.00	
10128		STA 60 LANDSCAPE MAINT 07/02/20	357-9557-795-18-00-60		75.00	
	* 107 Subtotal				125.00	
108	INVOICE: LANDSCAPE MAINT 08/13/20	STATUS: Printed				
10128		STA 60 LANDSCAPE MAINT 07/16/20	357-9557-795-18-00-60		50.00	
10128		STA 60 LANDSCAPE MAINT 08/13/20	357-9557-795-18-00-60		50.00	
	* 108 Subtotal				100.00	
	** MAHO001 Subtotal (2 Invoices)				225.00	
OPER001	VENDOR: OPERATING ENGINEERS					
HORST SEP 2020	INVOICE: OPEB 09/01/20	STATUS: Printed				
10136		SEP 2020 - HORST HEALTH INS	357-9557-795-03-30-R		1,497.00	
	* HORST SEP 2020 Subtotal				1,497.00	
	** OPER001 Subtotal (1 Invoice)				1,497.00	
PG&E001	VENDOR: PG&E					
69913707415 0721	INVOICE: ELECTRIC CHGS 07/22/20	STATUS: Printed				
10137		STA 62 ME 07/21/20 (2530.590500 kWh)	357-9557-795-30-00-E2		690.41	
10137		FS Bldg ME 07/21/20 (499.939000 kWh)	357-9557-795-30-00-EF		154.41	
10137		STA 64 ME 07/21/20 (316.546000 kWh)	357-9557-795-30-00-E4		105.59	
10137		STA 60 ME 07/21/20 (6904.180000 kWh)	357-9557-795-30-00-E0		1,939.61	
10137		STA 63 ME 07/21/20 (3217.902000 kWh)	357-9557-795-30-00-E3		862.32	
	* 69913707415 0721 Subtotal				3,752.34	
	** PG&E001 Subtotal (1 Invoice)				3,752.34	
PULL001	VENDOR: PULLMAN HEATING & COOLING INC					
PULLMAN08/04/20	INVOICE: HVAC REPR, UV INSTAL 08/04/20	STATUS: Printed				
10138		STA 60 HVAC REPAIR	357-9557-795-18-00-60		150.00	
10138		STA 60 UVC LIGHT INSTALL + MATERIAL	357-9557-795-18-00-60		1,830.00	
10138		STA 63 UVC LIGHT INSTALL + ELECTRIC	357-9557-795-18-00-63		400.00	
10138		STA 62 UVC LIGHT INSTALL + MATERIAL	357-9557-795-18-00-62		860.00	
10138		STA 60 HEAT PUMP FOR DRY STORAGE RO	357-9557-795-18-00-60		1,548.45	
	* PULLMAN08/04/20 Subtotal				4,788.45	
	** PULL001 Subtotal (1 Invoice)				4,788.45	
S&K PAVING	VENDOR: S&K PAVING SEALING & STRIPING, INC					
3002-20	INVOICE: PAVE, SEAL, STRIP, P 08/07/20	STATUS: Printed				
10139		35687 SQ FT SEAL COAT X 2	357-9557-795-18-00-60	S&K PAVING SEALING & STRIPING, INC	13,560.00	
10139		3000 FT CRACK FILLER	357-9557-795-18-00-60	S&K PAVING SEALING & STRIPING, INC	3,000.00	
10139		55 STRIPES, 2 HANDICAP, 1-8' HASH A	357-9557-795-18-00-60	S&K PAVING SEALING & STRIPING, INC	1,085.00	
	* 3002-20 Subtotal				17,645.00	
	** S&K PAVING Subtotal (1 Invoice)				17,645.00	
USBA001	VENDOR: US BANK					
821658	INVOICE: MEDICAL SUPPLIES ORG 07/12/20	STATUS: Approved				
		M6211 ACRYLIC ORGANIZER	357-9557-795-28-48-62	PARAMEDIC DESIGN INC	338.85	
	* 821658 Subtotal				338.85	
9172245	INVOICE: TRNG SUPPLIES B17/18 07/14/20	STATUS: Approved				
		WHITEBOARD 40x28 MAGNETIC DRY ERASE	357-9557-795-28-30-TB	AMAZON	428.79	CAL FIRE TRAINING BUREAU FUNDS
		DRY ERASE MARKERS CHISEL TIP ASST'D	357-9557-795-28-30-TB	AMAZON	42.81	CAL FIRE TRAINING BUREAU FUNDS
		DRY ERASE MARKERS CHISEL TIP 6 PIEC	357-9557-795-28-30-TB	AMAZON	29.52	CAL FIRE TRAINING BUREAU FUNDS
	* 9172245 Subtotal				501.12	
	** USBA001 Subtotal (2 Invoices)				839.97	

Voucher No	Vendor Name	Line Item Description	Budget Exp Acct	Merchant Vendor Name	Line Net Amt	Req No / Descr 2
USBA002	VENDOR: U.S.BANK					
02-116796	073120	INVOICE: REFUSE/RECYCLE COLLE 07/31/20 STATUS: Approved STA 62 ME 07/31/20	357-9557-795-30-00-G2	SOUTH LAKE REFUSE	69.48	
* 02-116796 073120 Subtotal					69.48	
02-152940	073120	INVOICE: REFUSE/RECYCLE COLLE 07/31/20 STATUS: Approved STA 60 ME 07/31/20	357-9557-795-30-00-G0	SOUTH LAKE REFUSE	306.71	
* 02-152940 073120 Subtotal					306.71	
02-601722	073120	INVOICE: REFUSE/RECYCLE COLLE 07/31/20 STATUS: Approved STA 63 ME 07/31/20	357-9557-795-30-00-G3	SOUTH LAKE REFUSE	82.30	
* 02-601722 073120 Subtotal					82.30	
06557	INVOICE: OFFICE AND CLEANING 07/20/20 STATUS: Approved					
		STA 63 HP 962 BLACK	357-9557-795-22-70-63	WALMART	64.13	
		STA 63 HP 962 BLACK	357-9557-795-22-70-63	WALMART	64.13	
		STA 63 GAIN LQD	357-9557-795-14-00-63	WALMART	10.81	
		STA 63 GAIN LQD	357-9557-795-14-00-63	WALMART	10.81	
		STA 63 12/200 FIL	357-9557-795-14-00-63	WALMART	1.50	
		STA 63 12/200 FIL	357-9557-795-14-00-63	WALMART	1.50	
		STA 63 CARRY BAG	357-9557-795-14-00-63	WALMART	0.10	
* 06557 Subtotal					152.98	
1356240	INVOICE: EXTENDED FIRELINE SU 07/04/20 STATUS: Approved					
		WT6011 JET BOIL COFFEE MAKER	357-9557-795-28-30-60	AMAZON	18.47	
		WT6411 JET BOIL COFFEE MAKER	357-9557-795-28-30-64	AMAZON	18.47	
		WT6011 JET BOIL FUEL	357-9557-795-28-30-60	AMAZON	19.50	
		WT6411 JET BOIL FUEL	357-9557-795-28-30-64	AMAZON	19.50	
		WT6011 MOUNTAIN HOUSE BUCKET FOOD	357-9557-795-28-30-60	AMAZON	56.59	
		WT6411 MOUNTAIN HOUSE BUCKET FOOD	357-9557-795-28-30-64	AMAZON	56.60	
* 1356240 Subtotal					189.13	
159992-722	INVOICE: PG&E ELECTRICAL SAFE 07/22/20 STATUS: Approved					
		23.5"W X 71.5"H X .09 FIBERGLASS DI	357-9557-795-28-30-PG	The Pannier Corporation	2,904.50	PG&E GRANT FUNDS
* 159992-722 Subtotal					2,904.50	
179951	INVOICE: PORTABLE LIGHTS M631 07/24/20 STATUS: Approved					
		M6311 FIRE VULCAN LED-ORANGE/STANDA	357-9557-795-28-48-63	ANDAX INDUSTRIES	362.68	
* 179951 Subtotal					362.68	
181589790	INVOICE: COMPUTER MEMORY 07/29/20 STATUS: Approved					
		STA 63 CRUCIAL 64 GB KIT	357-9557-795-28-30-63	NEWEGG BUSINESS INC	332.46	
		STA 62 CRUCIAL 64 GB KIT	357-9557-795-28-30-62	NEWEGG BUSINESS INC	332.46	
		STA 60 CRUCIAL 64 GB KIT	357-9557-795-28-30-60	NEWEGG BUSINESS INC	997.40	
* 181589790 Subtotal					1,662.32	
21910883	INVOICE: MEDICAL OXYGEN RENTA 06/30/20 STATUS: Approved					
		ME 06/30/20	357-9557-795-19-40-0	MATHESON TRI-GAS INC	30.95	
* 21910883 Subtotal					30.95	
22066892	INVOICE: MEDICAL OXYGEN RENTA 07/31/20 STATUS: Approved					
		ME 07/31/20	357-9557-795-19-40-0	MATHESON TRI-GAS INC	31.77	
* 22066892 Subtotal					31.77	
3005203319	INVOICE: MED WASTE DISPOSAL 07/31/20 STATUS: Approved					
		COLLECTED 07/20/20	357-9557-795-19-40-MW	STERICYCLE INC	0.26	
* 3005203319 Subtotal					0.26	

Voucher No	Vendor Name	Line Item Description	Budget Exp Acct	Merchant Vendor Name	Line Net Amt	Req No / Descr 2
USBA002	VENDOR: U.S.BANK					
30128147	081620	INVOICE: INTERNET SVC 07/07/20 STATUS: Approved STA 63 ME 08/16/20	357-9557-795-30-00-I3	MEDIACOM	67.64	
* 30128147 081620 Subtotal					67.64	
30165883	082620	INVOICE: INTERNET SVC 07/17/20 STATUS: Approved STA 62 ME 08/26/20	357-9557-795-30-00-I2	MEDIACOM	67.64	
* 30165883 082620 Subtotal					67.64	
30173705	082620	INVOICE: INTERNET SVC 07/17/20 STATUS: Approved STA 60 ME 08/26/20	357-9557-795-30-00-I0	MEDIACOM	57.99	
* 30173705 082620 Subtotal					57.99	
302086		INVOICE: EMS SUPPLIES 07/24/20 STATUS: Approved ORDER 552091	357-9557-795-19-40-MS	S&W HEALTHCARE CORP	444.84	
* 302086 Subtotal					444.84	
3072673M		INVOICE: PATIENT AUTO LOAD SY 07/15/20 STATUS: Approved M6311 POWERLOAD UPGRADE KIT M6211 POWERLOAD UPGRADE KIT	357-9557-795-62-74-63 357-9557-795-62-74-62	STRYKER STRYKER	1,718.84 1,718.84	
* 3072673M Subtotal					3,437.68	
3086617M		INVOICE: PATIENT AUTO LOAD SY 07/20/20 STATUS: Approved M6311 MTS POWERLOAD 2001012400065 M6211 MTS POWERLOAD 1909012400255	357-9557-795-62-74-63 357-9557-795-62-74-62	STRYKER STRYKER	25,346.45 25,346.44	
* 3086617M Subtotal					50,692.89	
35610401		INVOICE: BOARD MEETING REMOTE 08/11/20 STATUS: Approved ME 09/10/20, STANDARD PRO	357-9557-795-23-80-SP	ZOOM VIDEO COMMUNICATIONS INC	14.99	
* 35610401 Subtotal					14.99	
447800		INVOICE: CLEANING, BBQ REPAIR 07/07/20 STATUS: Approved STA 60 GAS VALVE FOR BBQ STA 60 LP ADAPTER FOR BBQ STA 60 BRASSO STA 60 THREAD SEAL TAPE STA 60 CAT LITTER STA 60 SOFT SWEEP BROOM	357-9557-795-14-00-60 357-9557-795-14-00-60 357-9557-795-14-00-60 357-9557-795-14-00-60 357-9557-795-14-00-60 357-9557-795-14-00-60	HARDESTERS HARDESTERS HARDESTERS HARDESTERS HARDESTERS HARDESTERS	12.86 31.09 9.63 1.49 3.81 21.44	
* 447800 Subtotal					80.32	
447814		INVOICE: CONEX STORING COVID 07/10/20 STATUS: Approved STA 60 SINGLE SIDE KEY	357-9557-795-17-00-60	HARDESTERS	5.98	
* 447814 Subtotal					5.98	
447815		INVOICE: RET'D REPR SUPPLIES 07/09/20 STATUS: Approved STA 60 VALVE GAS 1/2 FIP X1 STA 60 ADAPTR LP CYL TANK-5	357-9557-795-18-00-60 357-9557-795-18-00-60	HARDESTERS HARDESTERS	-12.86 -31.09	
* 447815 Subtotal					-43.95	
447852		INVOICE: GENERAL SUPPLIES FOR 07/05/20 STATUS: Approved STA 63 RSTP VOCOILENM SFTYE STA 63 RSTP VOCOILENM SFTRE STA 63 FOAM ROLLER 4 W/12 STA 63 STRAP EMT 1HOLE 1 STA 63 ORANGE GUARD 32 OZ STA 63 A&M W/S BLK 3/8X3/4X STA 63 FROG TAPE 1.88X60	357-9557-795-18-00-63 357-9557-795-18-00-63 357-9557-795-18-00-63 357-9557-795-18-00-63 357-9557-795-18-00-63 357-9557-795-18-00-63 357-9557-795-18-00-63	HARDESTERS HARDESTERS HARDESTERS HARDESTERS HARDESTERS HARDESTERS HARDESTERS	34.31 34.31 7.07 1.06 19.29 7.07 10.71	

Voucher No	Vendor Name	Line Item Description	Budget Exp Acct	Merchant Vendor Name	Line Net Amt	Req No / Descr 2
USBA002	VENDOR: U.S.BANK					
447852	INVOICE: GENERAL SUPPLIES FOR	07/05/20 STATUS: Approved				
		STA 63 FOAM MINI ROLLER 4	357-9557-795-18-00-63	HARDESTERS	6.43	
	* 447852 Subtotal				120.25	
448041	INVOICE: STA SAFETY SUPPLIES	07/24/20 STATUS: Approved				
		STA 60 DROPCLOTH 9X12	357-9557-795-18-00-60	HARDESTERS	5.35	COVID-19
		STA 60 DROPCLOTH 10X20	357-9557-795-18-00-60	HARDESTERS	5.35	COVID-19
		STA 60 PAINTERS TAPE	357-9557-795-18-00-60	HARDESTERS	19.28	COVID-19
		STA 60 COBBERT DUSTER	357-9557-795-18-00-60	HARDESTERS	12.86	COVID-19
		STA 60 SCOURING STICK	357-9557-795-18-00-60	HARDESTERS	4.93	COVID-19
	* 448041 Subtotal				47.77	
448115	INVOICE: APP BAY REFRIG REPR	07/13/20 STATUS: Approved				
		STA 60 GROUNDING PLUG 3WIRE	357-9557-795-14-00-60	HARDESTERS	15.00	
	* 448115 Subtotal				15.00	
450461	INVOICE: BBQ REPR SUPPLIES	07/16/20 STATUS: Approved				
		STA 60 FLARE UNION	357-9557-795-14-00-60	HARDESTERS	4.92	
		STA 60 THREADSEAL TAPE	357-9557-795-14-00-60	HARDESTERS	4.28	
		STA 60 GAS CONNECTOR	357-9557-795-14-00-60	HARDESTERS	27.88	
	* 450461 Subtotal				37.08	
450546	INVOICE: STA MAINT SUPPLIES	07/24/20 STATUS: Approved				
		STA 63 HINGE-RETURN	357-9557-795-18-00-63	HARDESTERS	-18.18	
		STA 63 HINGE	357-9557-795-18-00-63	HARDESTERS	19.25	
	* 450546 Subtotal				1.07	
452173	INVOICE: NAIL REMOVAL TOOL	07/28/20 STATUS: Approved				
		STA 60 VENT PROP NAIL REMOVAL TOOL	357-9557-795-18-00-60	HARDESTERS	75.06	
	* 452173 Subtotal				75.06	
454620	INVOICE: STA MAINT SUPPLIES	07/24/20 STATUS: Approved				
		STA 63 SERVER	357-9557-795-18-00-63	HARDESTERS	10.28	
		STA 63 AIR FILTER 14X	357-9557-795-18-00-63	HARDESTERS	21.41	
		STA 63 HINGE	357-9557-795-18-00-63	HARDESTERS	18.22	
	* 454620 Subtotal				49.91	
50050000 073120	INVOICE: WATER/SEWER	08/03/20 STATUS: Approved				
		STA 63 WATER ME 07/31/20 (601)	357-9557-795-30-00-W3	HIDDEN VALLEY LAKE CSD	55.69	
		STA 63 SEWER ME 07/31/20	357-9557-795-30-00-W3	HIDDEN VALLEY LAKE CSD	64.94	
	* 50050000 073120 Subtotal				120.63	
5473	INVOICE: PORTABLE LIGHTS M631	07/24/20 STATUS: Approved				
		STA 63 POSTAGE FOR RETURN	357-9557-795-22-71-63	MIDDLETOWN MAIL & MORE	53.19	
	* 5473 Subtotal				53.19	
57445237605	INVOICE: PROPANE	07/29/20 STATUS: Approved				
		STA 63 FILL 07/29/20	357-9557-795-30-00-P3	SHELL OIL	30.03	
	* 57445237605 Subtotal				30.03	
58183	INVOICE: HYDRATION FOR STA	07/17/20 STATUS: Approved				
		STA 60 5 GAL WATER	357-9557-795-13-00-60	ICE WATER CO	12.50	
		STA 62 5 GAL WATER	357-9557-795-13-00-62	ICE WATER CO	12.50	
		STA 63 5 GAL WATER	357-9557-795-13-00-63	ICE WATER CO	12.50	
	* 58183 Subtotal				37.50	
58351	INVOICE: HYDRATION FOR STA	07/31/20 STATUS: Approved				
		STA 62 BOTTLED WATER	357-9557-795-13-00-60	ICE WATER CO	12.50	

Voucher No	Vendor Name	Line Item Description	Budget Exp Acct	Merchant Vendor Name	Line Net Amt	Req No / Descr 2
USBA002	VENDOR: U.S.BANK					
58351	INVOICE: HYDRATION FOR STA 07/31/20	STATUS: Approved STA 63 BOTTLED WATER	357-9557-795-13-00-62	ICE WATER CO	12.50	
* 58351 Subtotal					25.00	
6508735-01	INVOICE: LEGAL NOTICE PUBLICA 08/06/20	STATUS: Approved 08/18/20 ADOPT 20-21 BUDGET	357-9557-795-23-80-SP	RECORD BEE	54.51	
* 6508735-01 Subtotal					54.51	
736/5	INVOICE: PROPANE REFILLS FOR 07/05/20	STATUS: Approved STA 60 5 GALLON SIZE REFILLS	357-9557-795-30-00-P0	RAINBOW AMERICA'S COUNTRY STORE	35.60	
* 736/5 Subtotal					35.60	
872847	INVOICE: COPIER MAINT 07/14/20	STATUS: Approved STA 60 QE 06/30/20 METER END 147283	357-9557-795-17-00-60	SMILE BUSINESS PRODUCTS	292.23	
* 872847 Subtotal					292.23	
9360088	INVOICE: OFFICE SUIPLIES 08/07/20	STATUS: Approved STA 60 PAPER 8-1/2x11 STA 60 HP 62XL BLACK INK STA 60 HP 62XL TRI-COLOR INK	357-9557-795-22-70-60 357-9557-795-22-70-60 357-9557-795-22-70-60	QUILL LLC QUILL LLC QUILL LLC	64.33 42.89 47.18	
* 9360088 Subtotal					154.40	
95183	INVOICE: CLEANING SUPPLIES 07/03/20	STATUS: Approved STA 63 PAPER TOWELS STA 63 409 STA 63 BUCKETS CASCADE STA 63 PINESOL STA 63 SUNLIGHT STA 63 CLOROX TOILET BOWL CLEANER STA 63 12"X1000 FOIL	357-9557-795-14-00-63 357-9557-795-14-00-63 357-9557-795-14-00-63 357-9557-795-14-00-63 357-9557-795-14-00-63 357-9557-795-14-00-63 357-9557-795-14-00-63	BOBS VACUUM BOBS VACUUM BOBS VACUUM BOBS VACUUM BOBS VACUUM BOBS VACUUM BOBS VACUUM	28.90 15.00 40.76 30.01 3.21 9.20 35.29	
* 95183 Subtotal					162.37	
95294	INVOICE: CLEANING SUPPLIES 07/17/20	STATUS: Approved STA 62 LAUNDRY XPRESS (3 GAL) STA 62 GERMICIDAL BLEACH (3 GAL) STA 62 HARD ROLL TOWEL (1 CS) STA 62 SINGLE FOLD TOWEL (1 CS) STA 62 SPRAYERS (4) STA 62 TOILET BOWL CLEANER (6)	357-9557-795-14-00-62 357-9557-795-14-00-62 357-9557-795-14-00-62 357-9557-795-14-00-62 357-9557-795-14-00-62 357-9557-795-14-00-62	BOBS VACUUM BOBS VACUUM BOBS VACUUM BOBS VACUUM BOBS VACUUM BOBS VACUUM	35.39 11.58 46.06 28.90 13.73 25.75	
* 95294 Subtotal					161.41	
95338	INVOICE: CLEANING SUPPLIES 07/24/20	STATUS: Approved STA 62 CASES S-FOLD	357-9557-795-14-00-62	BOBS VACUUM	86.71	
* 95338 Subtotal					86.71	
95392	INVOICE: CLEANING SUPPLIES 07/31/20	STATUS: Approved STA 60 NAPKIN DISPENSER STA 60 4500VN NAPKINS	357-9557-795-14-00-60 357-9557-795-14-00-60	BOBS VACUUM BOBS VACUUM	0.00 54.70	
* 95392 Subtotal					54.70	
95399	INVOICE: CLEANING SUPPLIES 07/24/20	STATUS: Approved STA 62 BLUE KITCHEN ROLL TOWELS STA 62 CASCADE STA 62 ZIPLOC 2 GAL	357-9557-795-14-00-62 357-9557-795-14-00-62 357-9557-795-14-00-62	BOBS VACUUM BOBS VACUUM BOBS VACUUM	10.72 40.75 21.35	
* 95399 Subtotal					72.82	
9859576938	INVOICE: CELLULAR SVC 07/26/20	STATUS: Approved M6211 ME 08/26/20 Booster Extender	357-9557-795-12-00-62	VERIZON WIRELESS	38.01	

Voucher No	Vendor Name	Line Item Description	Budget Exp Acct	Merchant Vendor Name	Line Net Amt	Req No / Descr 2
USBA002	VENDOR: U.S.BANK					
9859576938	INVOICE: CELLULAR SVC 07/26/20	STATUS: Approved				
	M6311 ME 08/26/20	Booster Extender	357-9557-795-12-00-63	VERIZON WIRELESS	38.01	
	M6211 ME 08/26/20	Tablet	357-9557-795-12-00-62	VERIZON WIRELESS	38.01	
	B1417 ME 08/26/20	Tablet	357-9557-795-12-00-A	VERIZON WIRELESS	16.02	
	B1418 ME 08/26/20	Tablet	357-9557-795-12-00-A	VERIZON WIRELESS	16.02	
	M6011 ME 08/26/20	Tablet	357-9557-795-12-00-60	VERIZON WIRELESS	16.02	
	E1487 ME 08/26/20	Tablet	357-9557-795-12-00-A	VERIZON WIRELESS	16.02	
	M6311 ME 08/26/20	Tablet	357-9557-795-12-00-63	VERIZON WIRELESS	16.02	
	M6012 ME 08/26/20	Cell Phone	357-9557-795-12-00-60	VERIZON WIRELESS	0.53	
	OES359 ME 08/26/20	Cell Phone	357-9557-795-12-00-60	VERIZON WIRELESS	0.53	
	Spare ME 08/26/20	Cell Phone	357-9557-795-12-00-60	VERIZON WIRELESS	0.53	
	M6011 ME 08/26/20	Cell Phone	357-9557-795-12-00-60	VERIZON WIRELESS	0.53	
	M6211 ME 08/26/20	Cell Phone	357-9557-795-12-00-62	VERIZON WIRELESS	0.53	
	M6311 ME 08/26/20	Cell Phone	357-9557-795-12-00-63	VERIZON WIRELESS	0.53	
	* 9859576938 Subtotal				197.31	
AF1F5586	INVOICE: PAINT REMOVAL, REPAI	07/18/20 STATUS: Approved				
	E6032 PAINT REMOVAL, REPAINT, RESTR		357-9557-795-17-00-60	HIDDEN VALLEY AUTO BODY	1,993.36	PO 21001 E6032
	* AF1F5586 Subtotal				1,993.36	
AR21-00023	INVOICE: EVOC ENROLLMENT FEE	07/13/20 STATUS: Approved				
	DELONG, CADEN		357-9557-795-28-30-T	SANTA ROSA JUNIOR COLLEGE/ACCOUNTIN	11.50	
	MYERS, SHELBY		357-9557-795-28-30-T	SANTA ROSA JUNIOR COLLEGE/ACCOUNTIN	11.50	
	VARGAS, NICK		357-9557-795-28-30-T	SANTA ROSA JUNIOR COLLEGE/ACCOUNTIN	11.50	
	* AR21-00023 Subtotal				34.50	
ORD FF42571	INVOICE: SUCTION INLET FIT BR	08/05/20 STATUS: Approved				
	E6321 KOCHEK 5' & 4' STORZ LOCK ASS		357-9557-795-17-00-63	FELD FIRE INC	66.24	
	* ORD FF42571 Subtotal				66.24	
T582031489981	INVOICE: BRIDGE TOLL 07/27/20	STATUS: Approved				
	U6321 TO 680 CROW CANYON ZONE SB 07		357-9557-795-17-00-63	FASTRAK VIOLATION PROCESSING DEPT	25.50	
	* T582031489981 Subtotal				25.50	
T712031331721	INVOICE: BRIDGE TOLL 07/27/20	STATUS: Approved				
	U6321 BENECIA-MARTINEZ BRIDGE 07/10		357-9557-795-17-00-63	FASTRAK VIOLATION PROCESSING DEPT	6.00	
	* T712031331721 Subtotal				6.00	
W061512	INVOICE: BAY DOOR REPAIR 07/29/20	STATUS: Approved				
	STA 60 GLASS REPL (90% BALANCE DUE)		357-9557-795-18-00-60	B&L GLASS COMPANY	1,011.00	
	* W061512 Subtotal				1,011.00	
** USBA002 Subtotal (49 Invoices)					65,640.25	
WITT001	VENDOR: WITTMAN ENTERPRISES					
2006043	INVOICE: AMBULANCE BILLING SV	07/28/20 STATUS: Printed				
10140	JUNE 2020		357-9557-795-23-80-AB		1,392.25	
	* 2006043 Subtotal				1,392.25	
** WITT001 Subtotal (1 Invoice)					1,392.25	
*** Grand Total (75 Invoices)					416,721.62	

**South Lake County
Fire Protection District
Cost Accounting Management System
Invoice Audit Trail**

Detail Report by Vendor, Invoice
Run Date: 08/14/2020 04:25:39pm By: GF
Fiscal Year: 2021

Selection Criteria

Select Inv Batch No
07/01/20, 07/21/20, 07/24/20

Report Template

AP Invoice Report Board Warrant List
\\Southlake\Lsladmin\Wincams\Lslfiles\Report\Criteria\AP Invoice Report Board Warrant List.rst

Voucher No	Vendor Name	Line Item Description	Budget Exp Acct	Merchant Vendor Name	Line Net Amt	Req No / Descr 2
ARBA001	VENDOR: ARBA					
8518AUG2020	INVOICE: GROUP LIFE FOR	PCFS 07/01/20	STATUS: Printed			
10107		AUG 2020 ATKINS	357-9557-795-03-30-G		8.32	
10107		AUG 2020 BULLOCK	357-9557-795-03-30-G		8.32	
10107		AUG 2020 CHASE	357-9557-795-03-30-G		8.32	
10107		AUG 2020 COLLINS	357-9557-795-03-30-G		8.32	
10107		AUG 2020 COSTA	357-9557-795-03-30-G		8.32	
10107		AUG 2020 DANIELS	357-9557-795-03-30-G		8.32	
10107		AUG 2020 DELONG	357-9557-795-03-30-G		8.32	
10107		AUG 2020 EMERSON	357-9557-795-03-30-G		8.32	
10107		AUG 2020 FANUCCHI	357-9557-795-03-30-G		8.32	
10107		AUG 2020 FENK	357-9557-795-03-30-G		8.32	
10107		AUG 2020 FLEENAR	357-9557-795-03-30-G		8.32	
10107		AUG 2020 FRAYER	357-9557-795-03-30-G		8.32	
10107		AUG 2020 HESS	357-9557-795-03-30-G		8.32	
10107		AUG 2020 HILDEBRAND	357-9557-795-03-30-G		8.32	
10107		AUG 2020 LANNING	357-9557-795-03-30-G		8.32	
10107		AUG 2020 LEUZINGER	357-9557-795-03-30-G		8.32	
10107		AUG 2020 LIBBY	357-9557-795-03-30-G		8.32	
10107		AUG 2020 LOPEZ	357-9557-795-03-30-G		8.32	
10107		AUG 2020 MCGEE	357-9557-795-03-30-G		8.32	
10107		AUG 2020 MIINCH	357-9557-795-03-30-G		8.32	
10107		AUG 2020 MYERS	357-9557-795-03-30-G		8.32	
10107		AUG 2020 NEWSOM	357-9557-795-03-30-G		8.32	
10107		AUG 2020 PARROTT	357-9557-795-03-30-G		8.32	
10107		AUG 2020 RYON	357-9557-795-03-30-G		8.32	
10107		AUG 2020 SMITH	357-9557-795-03-30-G		8.32	
10107		AUG 2020 TOTAGRANDE	357-9557-795-03-30-G		8.32	
10107		AUG 2020 VARGAS	357-9557-795-03-30-G		8.32	
10107		AUG 2020 ZIENTEK	357-9557-795-03-30-G		8.32	
		* 8518AUG2020 Subtotal			232.96	
		** ARBA001 Subtotal (1 Invoice)			232.96	
AT&T001	VENDOR: AT&T					
15042485	INVOICE: TELEPHONE CHGS	07/13/20	STATUS: Printed			
10108		Sta 64 ME 07/12/20	357-9557-795-30-00-T4		21.60	
10108		Sta 62 ME 07/12/20	357-9557-795-30-00-T2		47.90	
10108		Sta 63 ME 07/12/20	357-9557-795-30-00-T3		48.98	
10108		Sta 60 ME 07/12/20	357-9557-795-30-00-T0		170.93	
10108		FS Bldg ME 07/12/20	357-9557-795-30-00-TF		19.95	
		* 15042485 Subtotal			309.36	
		** AT&T001 Subtotal (1 Invoice)			309.36	
CALL001	VENDOR: CALLAYOMI CO WATER DISTRICT					
80 06/29/20	INVOICE: WATER	07/01/20	STATUS: Printed			
10109		STA 60 ME 06/29/20 (106620)	357-9557-795-30-00-W0		1,033.22	
		* 80 06/29/20 Subtotal			1,033.22	
81 06/29/20	INVOICE: WATER	07/01/20	STATUS: Printed			
10109		FS Bldg ME 06/29/20 (275)	357-9557-795-30-00-WF		34.54	
		* 81 06/29/20 Subtotal			34.54	
		** CALL001 Subtotal (2 Invoices)			1,067.76	
CASC001	VENDOR: CASCADE SOFTWARE SYSTEMS					
710-CSS	INVOICE: WINCAMS ACCTG SFTWR	07/01/20	STATUS: Printed			
10110		STA 60 YB 07/01/20	357-9557-795-17-00-60		1,000.00	
		* 710-CSS Subtotal			1,000.00	
		** CASC001 Subtotal (1 Invoice)			1,000.00	
COBB001	VENDOR: COBB AREA CO WATER DISTRICT					
185 06/22/20	INVOICE: WATER	06/22/20	STATUS: Printed			
10111		STA 62 ME 06/22/20 (8000)	357-9557-795-30-00-W2		120.76	
		* 185 06/22/20 Subtotal			120.76	
		** COBB001 Subtotal (1 Invoice)			120.76	

Voucher No	Vendor Name	Line Item Description	Budget Exp Acct	Merchant Vendor Name	Line Net Amt	Req No / Descr 2
DMV-LKPT VENDOR: DEPARTMENT OF MOTOR VEHICLES						
VIN20215 061820	INVOICE: REGISTRATION 06/18/20	STATUS: Printed				
10121	E6032 SALES TAX		357-9557-795-17-00-60		2,537.50	PO 21001 E6032
* VIN20215 061820 Subtotal					2,537.50	
** DMV-LKPT Subtotal (1 Invoice)					2,537.50	
FASI001 VENDOR: FASIS						
FASIS-2021-0195	INVOICE: WORKERS COMPENSATION 07/01/20	STATUS: Printed				
10112	NONSAFETY, CLERICAL QE 09/30/20		357-9557-795-04-00-NA		543.00	
10112	SAFETY, VOLUNTEER QE 09/30/20		357-9557-795-04-00-SW		2,104.00	
10112	SAFETY, VOLUNTEER BASE QE 09/30/20		357-9557-795-04-00-SB		2,726.00	
10112	NONSAFETY, MUNICIPALITY QE 09/30/20		357-9557-795-04-00-NM		65.00	
* FASIS-2021-0195 Subtotal					5,438.00	
** FASI001 Subtotal (1 Invoice)					5,438.00	
JERI001 VENDOR: JERI-CO GARAGE DOORS & OPERATIONS						
16421	INVOICE: BAY DOOR REPAIR 06/20/20	STATUS: Printed				
10113	STA 60 LIFTMASTER MH5011 & EXTRA RE		357-9557-795-18-00-60		900.00	
10113	STA 60 LABOR @ 4 HRS		357-9557-795-18-00-60		561.60	
* 16421 Subtotal					1,461.60	
16443	INVOICE: BAY DOOR REPAIR 06/15/20	STATUS: Printed				
10113	STA 60 DOOR #1 - LABOR		357-9557-795-18-00-60		105.00	
10113	STA 60 DOOR #1 - CABLE REPLACEMENT		357-9557-795-18-00-60		75.00	
10113	STA 60 DOOR #4 - CABLE REPLACEMENT		357-9557-795-18-00-60		75.00	
10113	STA 60 DOOR #1 & #4 - CABLE REPLACE		357-9557-795-18-00-60		180.00	
* 16443 Subtotal					435.00	
** JERI001 Subtotal (2 Invoices)					1,896.60	
LAKE001 VENDOR: LAKE COUNTY EMPLOYEES' ASSN						
HORST AUG 2020	INVOICE: OPEB 08/01/20	STATUS: Printed				
10122	AUG 2020 - HORST DUES		357-9557-795-03-30-R		31.64	
* HORST AUG 2020 Subtotal					31.64	
** LAKE001 Subtotal (1 Invoice)					31.64	
LAKE003 VENDOR: LAKE COUNTY SPECIAL DISTRICTS						
2200820 08/15/20	INVOICE: SEWER 06/16/20	STATUS: Printed				
10114	STA 60 ME 08/15/20 (0)		357-9557-795-30-00-S0		32.60	
* 2200820 08/15/20 Subtotal					32.60	
2202596 08/15/20	INVOICE: SEWER 06/16/20	STATUS: Printed				
10114	FS BLDG ME 08/15/20 (0)		357-9557-795-30-00-SF		32.60	
* 2202596 08/15/20 Subtotal					32.60	
** LAKE003 Subtotal (2 Invoices)					65.20	
LIFE001 VENDOR: LIFE ASSIST INC						
1015304	INVOICE: EMS SUPPLIES 07/02/20	STATUS: Printed				
10115	ORDER 57200534-1		357-9557-795-19-40-MS		1,686.57	
* 1015304 Subtotal					1,686.57	
** LIFE001 Subtotal (1 Invoice)					1,686.57	
LOCH001 VENDOR: LOCH LOMOND MUTUAL WATER						
31 07/21/20	INVOICE: WATER 07/23/20	STATUS: Printed				
10116	STA 64 ME 07/21/20 (0)		357-9557-795-30-00-W4		125.00	
* 31 07/21/20 Subtotal					125.00	
** LOCH001 Subtotal (1 Invoice)					125.00	
MIDD001 VENDOR: MIDDLETOWN COPY & PRINT						
2141	INVOICE: ELECTRICAL SAFETY PR 03/16/20	STATUS: Printed				
10117	GRAPHIC DESIGN ONLY FOR SIGNAGE 2'x		357-9557-795-28-30-PG		4,256.16	PG&E GRANT FUNDS
10117	STATION CLOSED TO PUBLIC 2'x3'		357-9557-795-28-30-PG		36.05	PG&E GRANT FUNDS
10117	STATION CLOSED TO PUBLIC 3'x4'		357-9557-795-28-30-PG		12.02	PG&E GRANT FUNDS
10117	STATION CLOSED TO PUBLIC 3'x4'		357-9557-795-28-30-PG		12.02	PG&E GRANT FUNDS
10117	SAMPLE PRINTOUT 2'x6'		357-9557-795-28-30-PG		4.21	PG&E GRANT FUNDS
10117	MAP 3'x4'		357-9557-795-28-30-PG		15.02	PG&E GRANT FUNDS

Voucher No	Vendor Name	Line Item Description	Budget Exp Acct	Merchant Vendor Name	Line Net Amt	Req No / Descr 2
MIDD001	VENDOR: MIDDLETOWN COPY & PRINT					
2141	INVOICE: ELECTRICAL SAFETY PR 03/16/20 STATUS: Printed					
10117		COPIES - YELLOW CARDSTOCK	357-9557-795-28-30-PG		7.51	PG&E GRANT FUNDS
* 2141 Subtotal					4,342.99	
2182	INVOICE: MAHA-GUENOC PRESENTA 07/08/20 STATUS: Printed					
10117		STA 60 FIRE PREVENTION BOOKS (154 P	357-9557-795-22-70-60		312.74	
10117		STA 60 FLYER - SAFETY ALERT 110# IN	357-9557-795-22-70-60		16.09	
* 2182 Subtotal					328.83	
** MIDD001 Subtotal (2 Invoices)					4,671.82	
OPER001	VENDOR: OPERATING ENGINEERS					
	HORST AUG 2020 INVOICE: OPEB 08/01/20 STATUS: Printed					
10123		AUG 2020 - HORST HEALTH INS	357-9557-795-03-30-R		1,497.00	
* HORST AUG 2020 Subtotal					1,497.00	
** OPER001 Subtotal (1 Invoice)					1,497.00	
PG&E001	VENDOR: PG&E					
	699137074150622 INVOICE: ELECTRIC CHGS 06/23/20 STATUS: Printed					
10118		STA 62 ME 06/22/20 (2502.322800 kWh	357-9557-795-30-00-E2		655.21	
10118		FS Bldg ME 06/22/20 (486.011000 kWh	357-9557-795-30-00-EF		149.85	
10118		STA 64 ME 06/22/20 (406.647000 kWh)	357-9557-795-30-00-E4		130.41	
10118		STA 60 ME 06/22/20 (4290.380000 kWh	357-9557-795-30-00-E0		1,295.66	
10118		STA 63 ME 06/22/20 (2955.154000 kWh	357-9557-795-30-00-E3		773.59	
* 699137074150622 Subtotal					3,004.72	
** PG&E001 Subtotal (1 Invoice)					3,004.72	
QUIL001	VENDOR: QUILL LLC					
	8588205 INVOICE: LABELMAKER REFILLS 07/14/20 STATUS: Printed					
10119		STA 60 PTOUCH TAPE 1/2IN BLK/WHT	357-9557-795-22-70-60		32.69	
10119		STA 62 PTOUCH TAPE 1/2IN BLK/WHT	357-9557-795-22-70-62		32.69	
* 8588205 Subtotal					65.38	
** QUIL001 Subtotal (1 Invoice)					65.38	
SOUT002	VENDOR: SOUTH LAKE COUNTY FIRE PROTECTION DIST					
	REST PYRL 20-21 INVOICE: REESTABLISH PYRL 07/01/20 STATUS: Printed					
10106		YB 07/01/20	357-9557-795-09-00-00		50,000.00	
* REST PYRL 20-21 Subtotal					50,000.00	
** SOUT002 Subtotal (1 Invoice)					50,000.00	
USBA001	VENDOR: US BANK					
	02-116796 063020 INVOICE: REFUSE/RECYCLE COLLE 06/30/20 STATUS: Printed					
10120		STA 62 ME 06/30/20	357-9557-795-30-00-G2	SOUTH LAKE REFUSE	65.55	
* 02-116796 063020 Subtotal					65.55	
	02-152940 063020 INVOICE: REFUSE/RECYCLE COLLE 06/30/20 STATUS: Printed					
10120		STA 60 ME 06/30/20	357-9557-795-30-00-G0	SOUTH LAKE REFUSE	81.40	
* 02-152940 063020 Subtotal					81.40	
	02-601722 063020 INVOICE: REFUSE/RECYCLE COLLE 06/30/20 STATUS: Printed					
10120		STA 63 ME 06/30/20	357-9557-795-30-00-G3	SOUTH LAKE REFUSE	77.64	
* 02-601722 063020 Subtotal					77.64	
	02-75450 INVOICE: MENS RR LIGHT FXT RE 07/05/20 STATUS: Printed					
10120		STA 60 ELECTRICAL SUPPLIES	357-9557-795-18-00-60	HARDESTERS	450.40	
* 02-75450 Subtotal					450.40	
	0423433 INVOICE: SUPPLIES TO SUPPORT 07/14/20 STATUS: Printed					
10120		STA 60 POLYCOM SOUNDSTATION2 EXPAND	357-9557-795-12-00-60	AMAZON	66.44	
* 0423433 Subtotal					66.44	
	062920 INVOICE: AC UNIT MAINT 06/29/20 STATUS: Printed					
10120		STA 62 T3D - UNIT REFRIGERANT LOW,	357-9557-795-18-00-62	FAHRENHEIT HEATING AND AIR CONDITIO	100.00	
10120		STA 62 410A REFRIGERANT	357-9557-795-18-00-62	FAHRENHEIT HEATING AND AIR CONDITIO	268.00	

Voucher No	Vendor Name	Line Item Description	Budget Exp Acct	Merchant Vendor Name	Line Net Amt	Req No / Descr 2
USBA001	VENDOR: US BANK					
062920	INVOICE: AC UNIT MAINT 06/29/20 STATUS: Printed					
10120		STA 62 LEAK STOP	357-9557-795-18-00-62	FAHRENHEIT HEATING AND AIR CONDITIO	150.00	
* 062920 Subtotal					518.00	
071118	INVOICE: AC UNIT MAINT-BILLED 07/11/18 STATUS: Printed					
10120		STA 62 DIAGNOSTIC- OTHER UNIT	357-9557-795-18-00-62	FAHRENHEIT HEATING AND AIR CONDITIO	70.00	
10120		STA 62 6 LBS REFRIGERANT - OTHER UN	357-9557-795-18-00-62	FAHRENHEIT HEATING AND AIR CONDITIO	402.00	
10120		STA 62 T2D - LIVING AREA UNIT	357-9557-795-18-00-62	FAHRENHEIT HEATING AND AIR CONDITIO	100.00	
* 071118 Subtotal					572.00	
1112197601	INVOICE: PROPANE 06/29/20 STATUS: Printed					
10120		STA 60 FILL 06/29/20	357-9557-795-30-00-P0	FERRELLGAS	191.13	
* 1112197601 Subtotal					191.13	
1143	INVOICE: EXTRICATION EQT SVC 06/26/20 STATUS: Printed					
10120		E1487 REPLACE CARBURATOR #17463hu	357-9557-795-17-00-A	WESTERN EXTRICATION SPECIALST INC	78.23	
10120		E1487 REPLACE CARRY HANDLE ON 5350	357-9557-795-17-00-A	WESTERN EXTRICATION SPECIALST INC	52.16	
10120		E1487 SERVICE SET TR5350/70 CARRY H	357-9557-795-17-00-A	WESTERN EXTRICATION SPECIALST INC	279.56	
10120		E1487 TRAVEL TIME	357-9557-795-17-00-A	WESTERN EXTRICATION SPECIALST INC	104.31	
10120		E1487 CARBURETOR GXH50Q	357-9557-795-17-00-A	WESTERN EXTRICATION SPECIALST INC	64.67	
* 1143 Subtotal					578.93	
1413485	INVOICE: NOMEX PANTS 06/16/20 STATUS: Printed					
10120		FANUCCHI, DOMINIC	357-9557-795-11-00-U	SANTA ROSA UNIFORM & CAREER APPAREL	185.25	
* 1413485 Subtotal					185.25	
146681	INVOICE: NOZZLE REPLACEMENT 07/06/20 STATUS: Printed					
10120		E6221 BRASS CHROME PLATED 2-1/2" NH	357-9557-795-28-30-62	FIRE HOSE DIRECT	110.37	
* 146681 Subtotal					110.37	
1611418	INVOICE: GPS UNITS E6221,E632 07/09/20 STATUS: Printed					
10120		E6221 GARMIN HANDHELD GPSMAP 64SX w	357-9557-795-28-30-62	AMAZON	287.90	
10120		E6321 GARMIN HANDHELD GPSMAP 64SX w	357-9557-795-28-30-63	AMAZON	287.90	
* 1611418 Subtotal					575.80	
179125	INVOICE: PORTABLE LIGHTS M631 07/10/20 STATUS: Printed					
10120		M6311 FIRE VULCAN LED-ORANGE/STANDA	357-9557-795-28-48-63	ANDAX INDUSTRIES	385.68	
* 179125 Subtotal					385.68	
300000770	INVOICE: ANNUAL MEMBERSHIP 07/01/20 STATUS: Printed					
10120		YB 07/01/20	357-9557-795-20-00-F	FDAC	200.00	
* 300000770 Subtotal					200.00	
30128147	INVOICE: INTERNET SVC 06/07/20 STATUS: Printed					
10120		STA 63 ME 07/16/20	357-9557-795-30-00-I3	MEDIACOM	67.64	
* 30128147 071620 Subtotal					67.64	
30165883	INVOICE: INTERNET SVC 06/17/20 STATUS: Printed					
10120		STA 62 ME 07/26/20	357-9557-795-30-00-I2	MEDIACOM	67.64	
* 30165883 072620 Subtotal					67.64	
30173705	INVOICE: INTERNET SVC 06/17/20 STATUS: Printed					
10120		STA 60 ME 07/26/20	357-9557-795-30-00-I0	MEDIACOM	57.99	
* 30173705 072620 Subtotal					57.99	
30522043	INVOICE: BOARD MEETING REMOTE 07/11/20 STATUS: Printed					
10120		ME 08/10/20, STANDARD PRO	357-9557-795-23-80-SP	ZOOM VIDEO COMMUNICATIONS INC	14.99	
* 30522043 Subtotal					14.99	
324868	INVOICE: FABRICATE, WELD SHEL 06/28/20 STATUS: Printed					
10120		STA 60 3/16x1-1/2x1-1/2 Alum Angre	357-9557-795-18-00-60	WEIDNERS WELDING	259.53	
10120		STA 60 Sq Ft 1/8" Alum Plate	357-9557-795-18-00-60	WEIDNERS WELDING	301.63	
10120		STA 60 Labor Welding/Fabricating sh	357-9557-795-18-00-60	WEIDNERS WELDING	900.00	
* 324868 Subtotal					1,461.16	

Voucher No	Vendor Name	Line Item Description	Budget Exp Acct	Merchant Vendor Name	Line Net Amt	Req No / Descr 2
USBA001	VENDOR: US BANK					
3515	INVOICE: FIRE PREPLAN SVC, SU 06/30/20	STATUS: Printed				
10120		B1417 TABLET QE 09/30/20	357-9557-795-28-30-A	HANGAR 14 SOLUTIONS LLC	45.00	
10120		B1418 TABLET QE 09/30/20	357-9557-795-28-30-A	HANGAR 14 SOLUTIONS LLC	45.00	
10120		E1487 TABLET QE 09/30/20	357-9557-795-28-30-A	HANGAR 14 SOLUTIONS LLC	45.00	
10120		M6211 TABLET QE 09/30/20	357-9557-795-28-30-62	HANGAR 14 SOLUTIONS LLC	45.00	
10120		M6311 TABLET QE 09/30/20	357-9557-795-28-30-63	HANGAR 14 SOLUTIONS LLC	45.00	
	* 3515 Subtotal				225.00	
399275	INVOICE: STRUCTURE GEAR 06/23/20	STATUS: Printed				
10120		G-XCEL JACKET GLOBE CUSTOM (5)	357-9557-795-11-00-P	LN CURTIS & SONS	6,998.06	
10120		GPS-SLIM JACKET GLOBE CUSTOM (2)	357-9557-795-11-00-P	LN CURTIS & SONS	2,243.67	
10120		GPS-REG PANT GLOBE CUSTOM (3)	357-9557-795-11-00-P	LN CURTIS & SONS	3,365.51	
	* 399275 Subtotal				12,607.24	
400492	INVOICE: WILD LAND GEAR 06/25/20	STATUS: Printed				
10120		YELLOW XL WILDLAND FIRE HELMET (5)	357-9557-795-11-00-P	LN CURTIS & SONS	304.32	
	* 400492 Subtotal				304.32	
45315	INVOICE: PEST CONTROL 07/15/20	STATUS: Printed				
10120		STA 63 RODENT BAIT STATIONS	357-9557-795-18-00-63	ARMED FORCE PEST CONTROL	20.00	
	* 45315 Subtotal				20.00	
50050000 063020	INVOICE: WATER/SEWER 07/01/20	STATUS: Printed				
10120		STA 63 Water ME 06/30/20 (648)	357-9557-795-30-00-W3	HIDDEN VALLEY LAKE CSD	56.95	
10120		STA 63 Sewer ME 06/30/20	357-9557-795-30-00-W3	HIDDEN VALLEY LAKE CSD	71.21	
	* 50050000 063020 Subtotal				128.16	
56345	INVOICE: HYDRATION FOR STA 06/19/20	STATUS: Printed				
10120		STA 60 BOTTLED WATER	357-9557-795-13-00-60	ICE WATER CO	6.25	
10120		STA 62 BOTTLED WATER	357-9557-795-13-00-62	ICE WATER CO	12.50	
10120		STA 63 BOTTLED WATER	357-9557-795-13-00-63	ICE WATER CO	12.50	
	* 56345 Subtotal				31.25	
60285A	INVOICE: SEWER CHECK-DUG UP S 05/19/20	STATUS: Printed				
10120		STA 62 HOURS OF PLUMBING	357-9557-795-18-00-62	ROTO-ROOTER OF LAKE COUNTY	169.36	
10120		STA 62 MATERIALS AND PARTS	357-9557-795-18-00-62	ROTO-ROOTER OF LAKE COUNTY	707.93	
	* 60285A Subtotal				877.29	
60361A	INVOICE: SEWER CHECK-DUG UP A 05/21/20	STATUS: Printed				
10120		STA 62 HOURS OF PLUMBING	357-9557-795-18-00-62	ROTO-ROOTER OF LAKE COUNTY	724.81	
10120		STA 62 VIDEO INSPECT	357-9557-795-18-00-62	ROTO-ROOTER OF LAKE COUNTY	100.67	
10120		STA 62 MATERIALS AND PARTS	357-9557-795-18-00-62	ROTO-ROOTER OF LAKE COUNTY	83.75	
	* 60361A Subtotal				909.23	
61512	INVOICE: BAY DOOR REPAIR 07/02/20	STATUS: Printed				
10120		STA 60 10% OF BID FOR GLASS REPL	357-9557-795-18-00-60	B&L GLASS COMPANY	112.00	
	* 61512 Subtotal				112.00	
6888268	INVOICE: EXTENDED FIRELINE SU 07/04/20	STATUS: Printed				
10120		WT6011 JETBOIL FLASH CAMPING STOVE	357-9557-795-28-30-60	AMAZON	117.92	
10120		WT6411 JETBOIL FLASH CAMPING STOVE	357-9557-795-28-30-64	AMAZON	117.92	
	* 6888268 Subtotal				235.84	
79646-01	INVOICE: POSTAGE 07/15/20	STATUS: Printed				
10120		STA 60 US FLAG COIL/100	357-9557-795-22-71-60	US POSTAL SERVICE	110.00	
	* 79646-01 Subtotal				110.00	
8869	INVOICE: INVENTORY APP ANNUAL 07/01/20	STATUS: Printed				
10120		STA 60 YB 07/31/20	357-9557-795-28-30-60	TARGET SOLUTIONS LEARNING LLC	280.25	
10120		STA 62 YB 07/31/20	357-9557-795-28-30-62	TARGET SOLUTIONS LEARNING LLC	280.25	
10120		STA 63 YB 07/31/20	357-9557-795-28-30-63	TARGET SOLUTIONS LEARNING LLC	280.25	
10120		STA 64 YB 07/31/20	357-9557-795-28-30-64	TARGET SOLUTIONS LEARNING LLC	280.25	
	* 8869 Subtotal				1,121.00	

Voucher No	Vendor Name	Line Item Description	Budget Exp Acct	Merchant Vendor Name	Line Net Amt	Req No / Descr 2
USBA001	VENDOR: US BANK					
9857521624	INVOICE: CELLULAR SVC 06/26/20 STATUS: Printed					
10120	M6211	ME 07/26/20 Booster Extender	357-9557-795-12-00-62	VERIZON WIRELESS	38.01	
10120	M6311	ME 07/26/20 Booster Extender	357-9557-795-12-00-63	VERIZON WIRELESS	38.01	
10120	M6211	ME 07/26/20 Tablet	357-9557-795-12-00-62	VERIZON WIRELESS	38.01	
10120	B1417	ME 07/26/20 Tablet	357-9557-795-12-00-A	VERIZON WIRELESS	16.02	
10120	B1418	ME 07/26/20 Tablet	357-9557-795-12-00-A	VERIZON WIRELESS	16.02	
10120	M6011	ME 07/26/20 Tablet	357-9557-795-12-00-60	VERIZON WIRELESS	16.02	
10120	E1487	ME 07/26/20 Tablet	357-9557-795-12-00-A	VERIZON WIRELESS	16.02	
10120	M6311	ME 07/26/20 Tablet	357-9557-795-12-00-63	VERIZON WIRELESS	16.02	
10120	M6012	ME 07/26/20 Cell Phone	357-9557-795-12-00-60	VERIZON WIRELESS	0.46	
10120	OES359	ME 07/26/20 Cell Phone	357-9557-795-12-00-60	VERIZON WIRELESS	0.46	
10120	Spare	ME 07/26/20 Cell Phone	357-9557-795-12-00-60	VERIZON WIRELESS	0.46	
10120	M6011	ME 07/26/20 Cell Phone	357-9557-795-12-00-60	VERIZON WIRELESS	0.46	
10120	M6211	ME 07/26/20 Cell Phone	357-9557-795-12-00-62	VERIZON WIRELESS	0.46	
10120	M6311	ME 07/26/20 Cell Phone	357-9557-795-12-00-63	VERIZON WIRELESS	0.46	
* 9857521624 Subtotal					196.89	
I-306387	INVOICE: COPY PAPER 07/10/20 STATUS: Printed					
10120		STA 60 PAPER 8.5x11 20LB	357-9557-795-22-70-60	THE PRIMARY SOURCE	81.36	
* I-306387 Subtotal					81.36	
SO1383804	INVOICE: THERMAL IMAGE CAMERA 07/05/20 STATUS: Printed					
10120	B1417	SEEK GEAR KEEPER W/ALUM CARAB	357-9557-795-28-30-A	MUNICIPAL EMERGENCY SERVICES	44.48	
* SO1383804 Subtotal					44.48	
SO572039	INVOICE: REPLACEMENT PART 07/06/20 STATUS: Printed					
10120	E6221	HERBERT HOSE CLAMP 2.5"	357-9557-795-27-00-62	LN CURTIS & SONS	312.65	
* SO572039 Subtotal					312.65	
** USBA001 Subtotal (35 Invoices)					23,044.72	
*** Grand Total (56 Invoices)					96,794.99	